

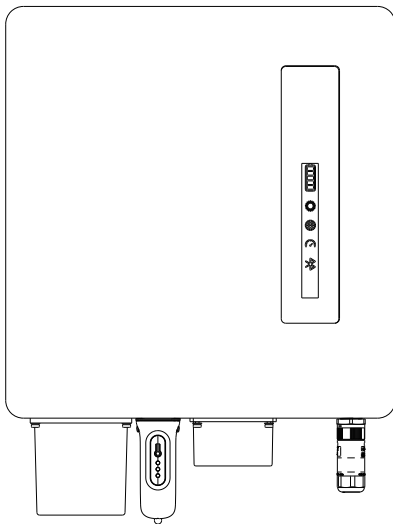

User Manual

for S6 Series AC Coupled Inverter



Applicable models
S6-EA1P(3.6-6)K-L

Applicable System
Single phase system

Important Notes

- Due to the product development, the product specifications and functions are subject to change. The latest manual can be acquired via <https://www.ginlong.com/global>. Every attempt has been made to make this document complete, accurate and up-to-date. Individuals reviewing this document and installers or service personnel are cautioned, however, that Solis reserves the right to make changes without notice and shall not be responsible for any damages, including indirect, incidental or consequential damages caused by reliance on the material presented including, but not limited to, omissions, typographical errors, arithmetical errors or listing errors in the material provided in this document.
- Solis accepts no liability for customers' failure to comply with the instructions for correct installation and will not be held responsible for upstream or downstream systems Solis equipment has supplied.
- The customer is fully liable for any modifications made to the system; therefore, any hardware or software modification, manipulation, or alteration not expressly approved by the manufacturer shall result in the immediate cancellation of the warranty.
- Given the countless possible system configurations and installation environments, it is essential to verify adherence to the following:
 - There is sufficient space suitable for housing the equipment.
 - Airborne noise produced depending on the environment.
 - Potential flammability hazards.
 - Solis will not be held liable for defects or malfunctions arising from:
 - Improper use of the equipment.
 - Deterioration resulting from transportation or particular environmental conditions.
 - Performing maintenance incorrectly or not at all.
 - Tampering or unsafe repairs.
 - Use or installation by unqualified persons.
 - This product contains lethal voltages and should be installed by qualified electrical or service personnel having experience with lethal voltages.

Contents

1. Introduction	01-03
1.1 Product Overview	01
1.2 Inverter Wire Box and Connection Points	02
1.3 Packaging	03
1.4 Tools Required for Installation	03
2. Safety & Warning	04-05
2.1 Safety	04
2.2 General Safety Instructions	04
2.3 Notice for Use	05
2.4 Notice for Disposal	05
3. Overview	06-07
3.1 Intelligent LED Indicators	06
3.2 Password Reset	07
4. Installation	08-24
4.1 Select a Location to Install the Inverter	08
4.2 Product Handling	09
4.3 Mounting the Inverter	11
4.4 Battery Cable Installation	13
4.5 AC Cable Installation	14
4.6 Ground Cable Installation	17
4.7 Meter/CT Installation	18
4.8 Communication Cable Installation	19
4.9 External Residual Current Device(RCD)	23
4.10 Inverter Remote Monitoring Connection	24
4.11 System Diagram	25
5. Commissioning	26-43
5.1 Pre-Commissioning	26
5.2 Power ON	26
5.3 Power OFF	26
5.4 Log in the APP via Bluetooth	27
5.5 Initial set up	28
5.6 APP Interface	32
5.7 Australian Grid Code Settings	39
5.8 Export Power Control	43
6. Maintenance	44
7. Troubleshooting	45
8. Specifications	48

1.1 Product Overview

The Solis S6-EA1P(3.6-6)K-L series is designed for upgrading the existing on-grid power generation system to a hybrid system which can work with batteries to optimize self-consumption.

The S6-EA1P(3.6-6)K-L series consists of the following inverter models:

3.6kW,4.6kW,5kW,6kW.

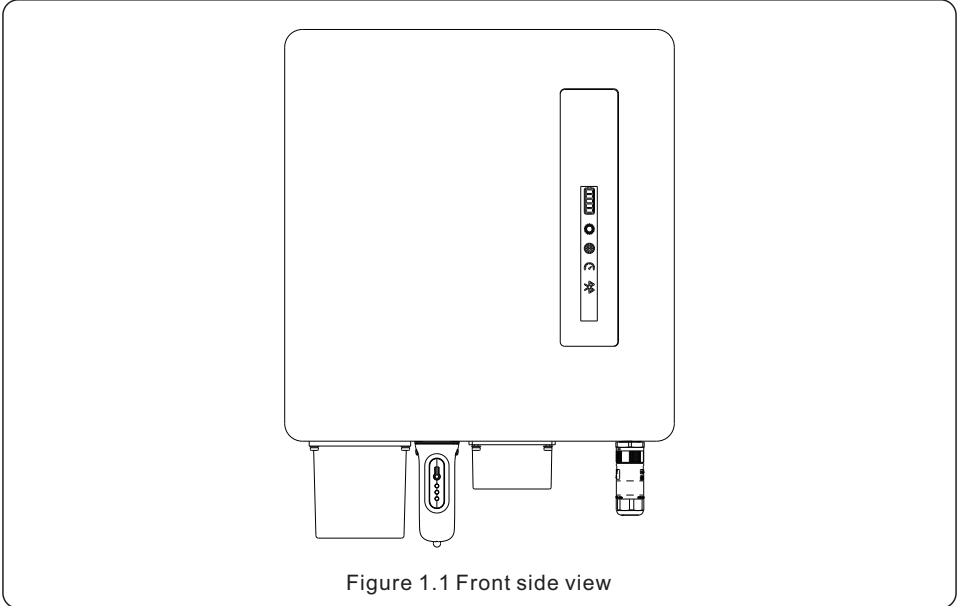

Figure 1.1 Front side view

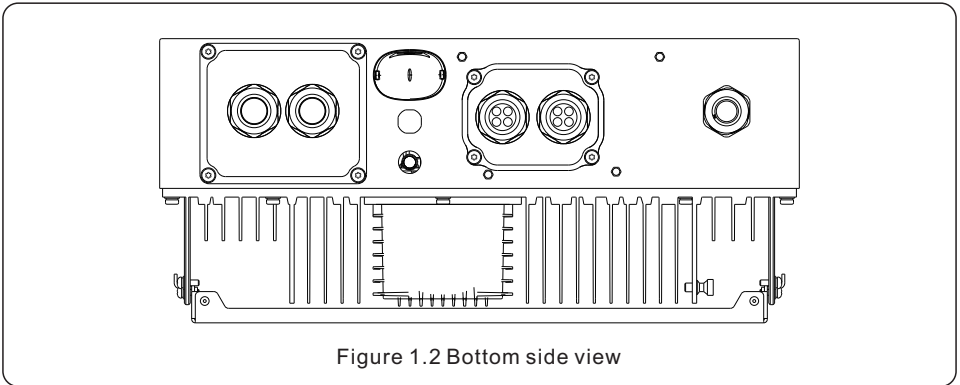
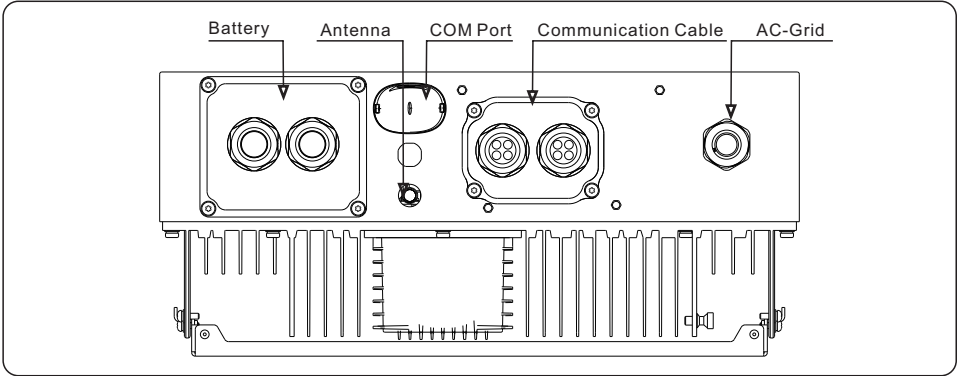

Figure 1.2 Bottom side view

1.2 Inverter Wire Box and Connection Points



Name	Description
1. Battery	Conduit for Battery conductors should be connected here
2. Antenna	Extends the range of the inverter Bluetooth signal(for system commissioning)
3. COM Port	Solis data logger gets connected here-only USB version of the loggers will work
4. Communication Cable	RS485 and CAN communication cables and parallel cables should go through these
5. AC-Grid	Conduit for AC conductors to the main service panel should be connected here

1.3 Packaging

Please ensure that the following items are included in the packaging with your machine:

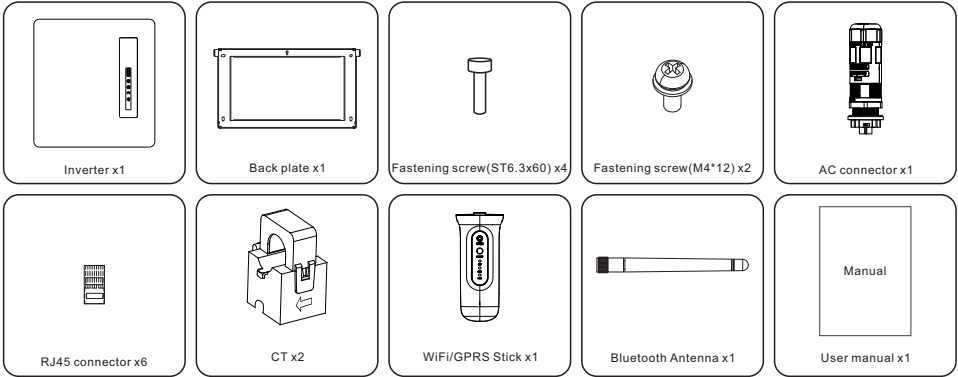

If anything is missing, please contact your local Solis distributor.

1.4 Tools Required for Installation



2.1 Safety

The following types of safety instructions and general information appear in this document as described below:



Please read safety instructions carefully in the manual.



DANGER

“Danger” indicates a hazardous situation which if not avoided, will result in death or serious injury.



WARNING

“Warning” indicates a hazardous situation which if not avoided, could result in death or serious injury.



CAUTION

“Caution” indicates a hazardous situation which if not avoided, could result in minor or moderate injury.



NOTE

“Note” provides tips that are valuable for the optimal operation of your product.

2.2 General Safety Instructions



WARNING

Only devices in compliance with SELV (EN 69050) may be connected to the RS485 and USB interfaces.



WARNING

Electrical installations must be done in accordance with local and national electrical safety standards.



CAUTION:

Risk of electric shock, do not remove cover. There is no user serviceable parts inside, refer servicing to qualified and accredited service technicians.



CAUTION:

Risk of electric shock from energy stored in capacitors of the Inverter, do not remove cover for 5 minutes after disconnecting all power sources (service technician only). Warranty may be voided if the cover is removed without authorization .



CAUTION:

The surface temperature of the inverter can reach up to 75°C. To avoid risk of burns, do not touch the surface of the inverter while it's operating. Inverter must be installed out of the reach of children.



WARNING:

Operations below must be accomplished by licensed technician or Solis authorized person.



WARNING:

Operator must put on the technicians' gloves during the whole process in case of any electrical hazards.

2.3 Notice for Use

The inverter has been constructed according to the applicable safety and technical guidelines, use the inverter in installations that meet the following specifications only:

1. Permanent installation is required.
2. The electrical installation must be compliant with all local and national regulations & standards.
3. The inverter must be installed according to the instructions stated in this manual.
4. The inverter must be installed according to the inverter technical specifications.
5. The single-phase inverter is not permitted to make-up three-phase system.
6. The inverter has not been tested to AS/NZS 4777.2:2020 for multiple inverter combinations and/or multiple phase inverter combinations so combinations should not be used or external devices should be used in accordance with the requirements of AS/NZS 4777.1.

2.4 Notice for Disposal

This product shall not be disposed of with household waste.

It must be segregated and brought to an appropriate disposal facility to ensure proper recycling.

This is to be done in order to avoid negative impacts on the environment and human health.



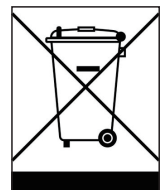

Local waste management rules shall be observed and respected.



3.1 Intelligent LED Indicators

There are five indicators on the The Solis S6-EA1P(3.6-6)K-L Series Inverter(Battery, Power, COM, CT/Meter and Bluetooth) which indicate the working status of the inverter.

The Bluetooth Antenna or WiFi/WL data logger shall be installed at the Antenna/COM port of the hybrid inverter before local debugging.

Light	Status	Description
 Battery	Blue Flashing every 3s	Battery discharging.
	Blue Flashing every 1.5s	Battery charging.
	Blue Solid ON	Idle.
	Yellow Solid ON	Battery Warning.
 Power	Blue Solid ON	Normally Operating.
	Yellow Solid ON	Warning.
	Red Solid ON	Alarm.
 WiFi	Blue Solid ON	COM Port is using.
	OFF	COM Port is not used.
 RS485	Blue Solid ON	RS485 Port is using.
	OFF	RS485 Port is not used.
 Bluetooth	Blue Solid ON	Bluetooth Port is using.
	OFF	Bluetooth Port is not used.

Turning On the LED Indicator Lights

After a few minutes, the LED indicator lights will turn off to conserve power. To turn the lights back on, short-press the Inverter LED light.



Alarm State

When the inverter has an alarm, the Inverter LED light turns red and starts flashing. It is recommended to connect to the inverter with the Bluetooth tool. Then you can determine what the alarm code is.



NOTE:

Battery/WiFi/Ethernet/Bluetooth indicators will automatically turn off after 1 minute. The Power indicator will remain on with lower brightness. Short press the Power indicator can wake up all indicators.

3.2 Password Reset

When the password of the owner or the installer needs to be reset, please long press the Inverter indicator for 5s.

If the reset command is successfully triggered, the status indicator will be blue and blink for 3s at the frequency of 0.5s, then restore the original state of the indicator.

If the command fails to be triggered, the status indicator will be yellow and blink for 3s at the frequency of 0.5s, then restore the original state of the indicator.

If the command is successfully triggered, the Bluetooth password can be reset in the APP.

4.1 Select a Location to Install the Inverter

When selecting a location for the inverter, the following criteria should be considered:

- Exposure to direct sunlight may cause output power derating due to overheating. It is recommended to avoid installing the inverter in direct sunlight. The ideal location is one where the ambient temperature does not exceed 40°C.
- It is also recommended to install the inverter somewhere the rain and snow will not land directly on it.
- The inverter with protection rating IP66 can be installed both indoors and outdoors.

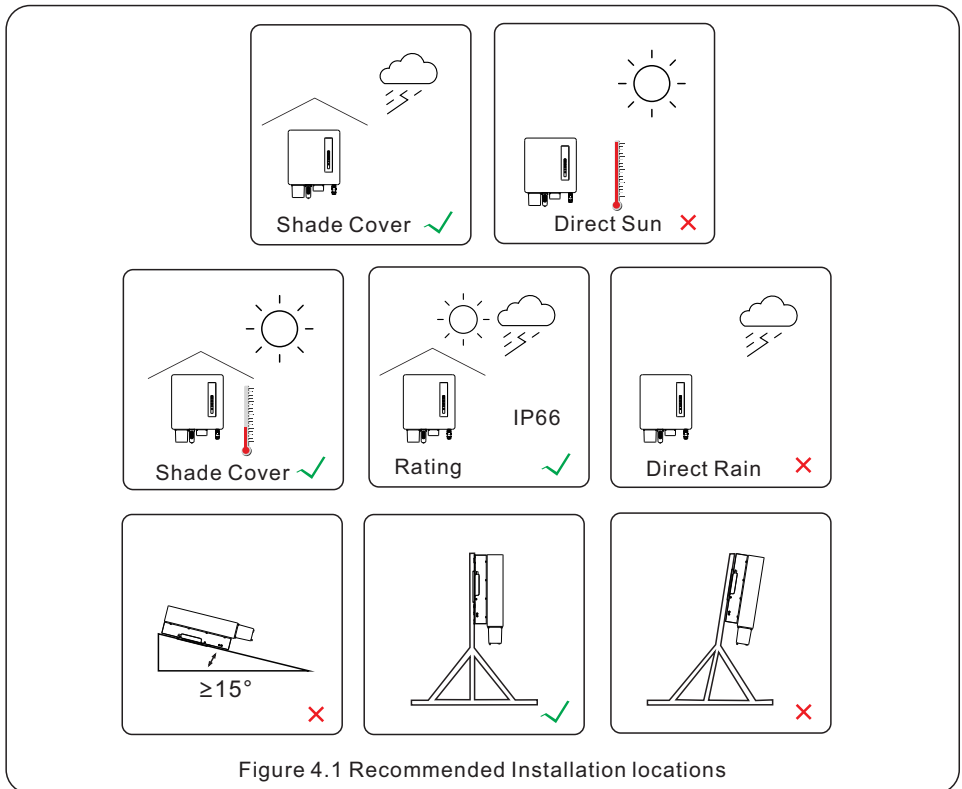

WARNING: Risk of fire

Despite careful construction, electrical devices can cause fires.

- Do not install the inverter in areas containing highly flammable materials or gases.
- Do not install the inverter in potentially explosive atmospheres.
- The mounting structure where the inverter is installed must be fireproof.



When selecting a location for the inverter, consider the following:



CAUTION: Hot Surface

- The temperature of the inverter heat-sink can reach 75°C.

The ambient temperature and relative humidity of the installation environment should meet the following requirements:

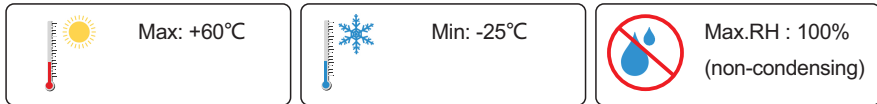

Figure 4.2 Installation environment conditions



Load bearing surface:

Made of non-inflammable materials



Max. load bearing capacity \geq 4 times of inverter weight

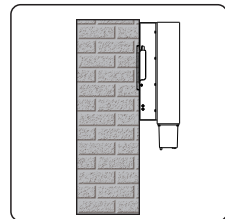

Figure 4.3 Load bearing structure

4.1.1 Clearances

- If multiple inverters are installed on site, a minimum clearance of 250mm should be kept between each inverter and all other mounted equipment. The bottom of the inverter should be at least 800mm above of the ground or floor.
- The LED status indicator lights located on the inverter's front panel should not be blocked
- Adequate ventilation must be present if the inverter is to be installed in a confined space.

4.1.2 Consult technical data

- Consult the technical specifications sections at the end of this manual for additional environmental condition requirements (temperature range, altitude, etc.)

4.1.3 Angle of installation

- This model of Solis inverter must be mounted vertically (90 degrees or backwards less than or equal to 15 degrees from 90 degrees straight up).

4.1.4 Avoiding direct sunlight

Installation of the inverter in a location exposed to direct sunlight should to be avoided.

Direct exposure to sunlight could cause:

- Power output limitation (with a resulting decreased energy production by the system).
- Premature wear of the electrical/electromechanical components.
- Premature wear of the mechanical components (gaskets) and user interface.

4.1.5 Air circulation

Do not install in small, closed rooms where air cannot freely circulate.

To prevent overheating, always ensure that the air flow around the inverter is not blocked.

4.1.6 Flammable substances

Do not install near flammable substances. Maintain a minimum distance of three meters (10 feet) from such substances.

4.1.7 Heatsource

Do not install near heat source. Maintain a minimum distance of three meters (10 feet) from any heat source.

4.1.8 Living area

Do not install in a living area where the prolonged presence of people or animals is expected. Depending on where the inverter is installed (for example: the type of surface around the inverter, the general properties of the room, etc.) and the quality of the electricity supply, the sound level from the inverter can be quite high.

4.2 Product Handling

Please review the instruction below for handling the inverter:

1. The red circles below denote cutouts on the product package.

Push in the cutouts to form handles for moving the inverter (see Figure 4.4).

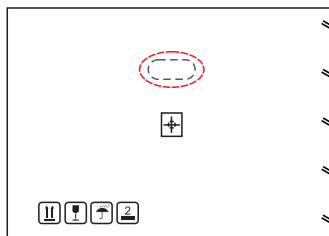

Figure 4.4 Handles used to move the inverter shown circled in red - one per side

2. Two people are required to remove the inverter from the shipping box. Use the handles integrated into the heat sink to remove the inverter from the carton.
3. When setting the inverter down, do it slowly and gently. This ensures that the internal components and the outer chassis do not take any damage.

4.3 Inverter Transport and Storage

Transport the inverter in its original packaging, facing up and without exposing it to unnecessary shocks. If the original package is no longer available, use a similar box that can withstand the weight of the inverter (refer to the inverter weight in the specification datasheet provided with the unit), has a handle system and can be closed fully.

Store the inverter in a dry place where ambient temperatures are between -25°C to $+60^{\circ}\text{C}$.

4.4 Mounting the Inverter

- Mount the inverter on a wall or structure capable of bearing the weight of the machine.
- The inverter must be mounted vertically with a maximum incline of ± 5 degree. Exceeding this may cause the output power to derate.
- To avoid overheating, always make sure the flow of air around the inverter is not blocked. A minimum clearance of 250mm should be kept between inverters or objects and 800mm clearance between the bottom of the machine and the ground.

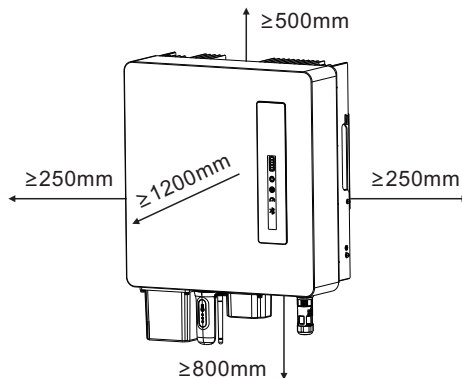

Figure 4.5 Inverter Mounting Clearances

- Visibility of the LED indicator lights should be considered.
- Adequate ventilation around the inverter must be provided.



NOTE

Nothing should be stored on top of or placed against the inverter.

Dimensions of mounting bracket:

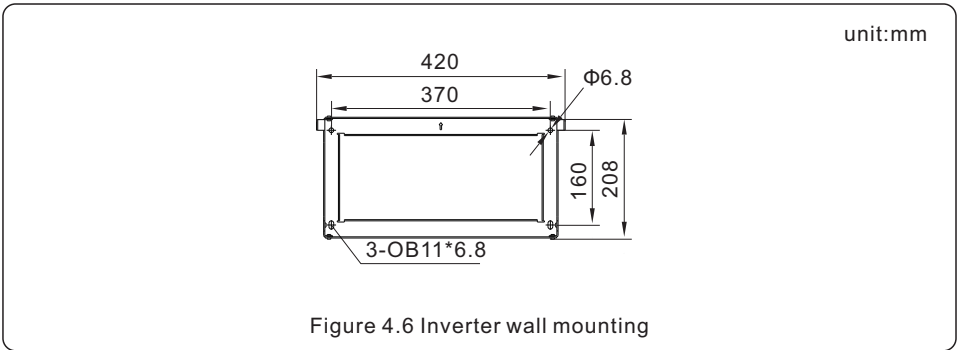

Once a suitable location has been found according to 4.1 using figure 4.6 mount the wall bracket to the wall.

The inverter shall be mounted vertically.

The steps to mount the inverter are listed below:

1. Select the mounting height of the bracket and mark the mounting holes.
For brick walls, the position of the holes should be suitable for the expansion bolts.
2. Lift up the inverter (be careful to avoid body strain), and align the back bracket on the inverter with the convex section of the mounting bracket. Hang the inverter on the mounting bracket and make sure the inverter is secure (see Figure 4.7)

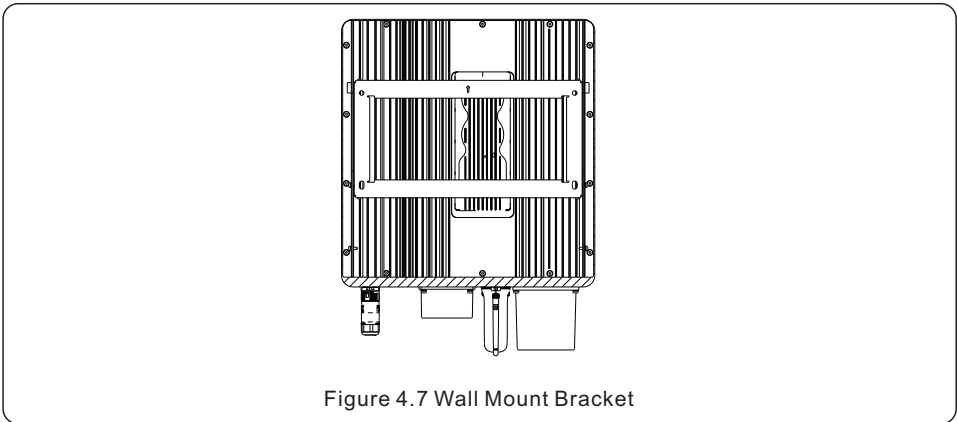

WARNING:
The inverter must be mounted vertically.

4.5 Battery Cable Installation



WARNING:

Incorrect polarity of the battery cable may lead to permanent damage on the device.



WARNING:

To avoid DC arc, Solis recommends installing DC breaker between batteries and the AC coupled inverter.

DC breaker: 100A for 3.6K, 160A for (4.6-6)K.

Ensure the correct polarity of batteries before connecting to the inverter.

Step 1. Please unlock the 4*M4 screws on the battery port protection cover as shown in the below figure.

Step 2. Insert the battery power cables into the water-proof swivel nut on the cover,(Break the plastic film on it).

Step 3. Fasten the battery power cables onto the BAT+ and BAT- terminals on the inverter. Please make sure the labels on cable and inverter match up.

Step 4. Lock the 4*M4 screws and fix the cover onto the inverter.

Step 5. Connect the other side of the battery power cables to the battery.

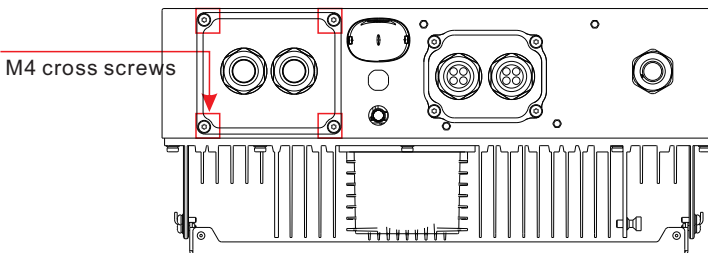

Figure 4.8

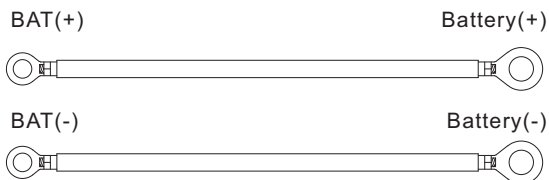

Figure 4.9

4.6 AC Cable Installation

For all AC connections, 2.5- 6mm² cable is required to be used. Please make sure the resistance of cable is lower than 1 ohm. If the wire is longer than 20m, it's recommended to use 6mm² cable.



There are "L", "N", "PE" symbols marked inside the connector, the Line wire of grid must be connected to "L" terminal, the Neutral wire of grid must be connected to "N" terminal and Earth wire must be connected to "PE".

Cable type	Cross section (mm ²)	
	Range	Recommended value
Industry generic grid cable	2.5~6.0	6.0

Table 4.1 Grid cable size

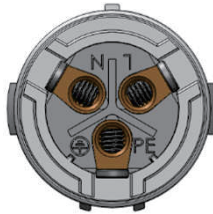

Figure 4.10 AC Grid Terminal Connector Inside

Each Solis S6 Single Phase Inverter is supplied with an AC grid terminal connector.

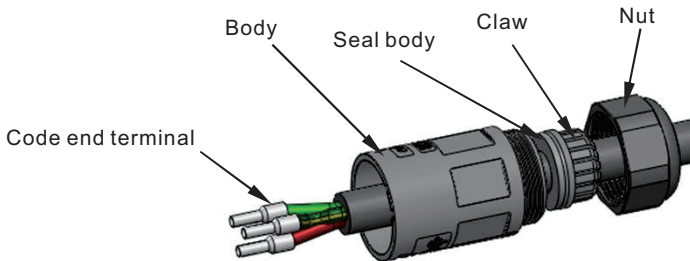

Figure 4.11 AC Grid Terminal Connector

The steps to assemble the AC grid terminal connectors are listed as follows:

1. Disassemble the AC connector. Strip the AC wires about 7mm.

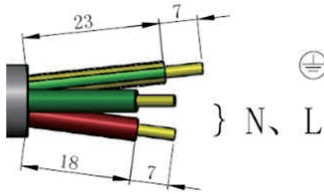

Figure 4.12 Stripped AC Wires

2. Fix the wires into the correct position. Torque 0.8N.m
Please try to pull out the wire to make sure it's well connected.

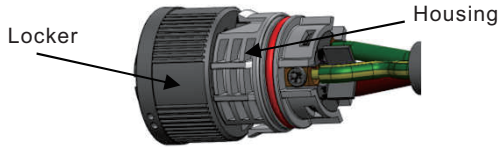

Figure 4.13 Connect Wires to the Terminal

3. Insert Seal and Clamp Finger into body ,then tighten the nut, torque 2.5+/-0.5N.m.



Figure 4.14 Tighten up the Cap on the Terminal

4. Mating plug and socket:

Push the locker onto the socket housing completely, then rotate the locker according to the direction instructed by the marks on the locker. (Warning: hold the body)

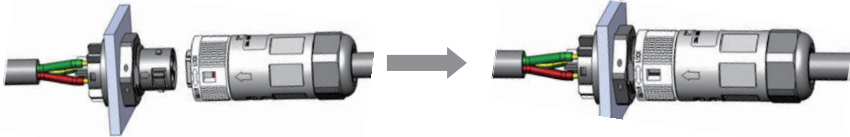

Figure 4.15 Connect the AC Connector to the Inverter

Inverter	Rated output voltage(V)	Rated output current (A)	Current for protection device (A)
S6-EA1P3.6K-L	220/230	16.4/15.7	40
S6-EA1P4.6K-L	220/230	21.0/20.0	40
S6-EA1P5K-L	220/230	22.8/21.8	40
S6-EA1P6K-L	220/230	27.3/26.1	40

Table 4.2 Rating of grid OCPD



NOTE

For AC connectors, the separation of the male and female ends requires a tool to disassemble and requires a force greater than 20N.

4.7 Ground Cable Installation

An external ground connection is provided at the right side of inverter. Prepare OT terminals: M4. Use proper tooling to crimp the lug to the terminal. Connect the OT terminal with ground cable 8 AWG to the right side of inverter. The torque is 2N.m.

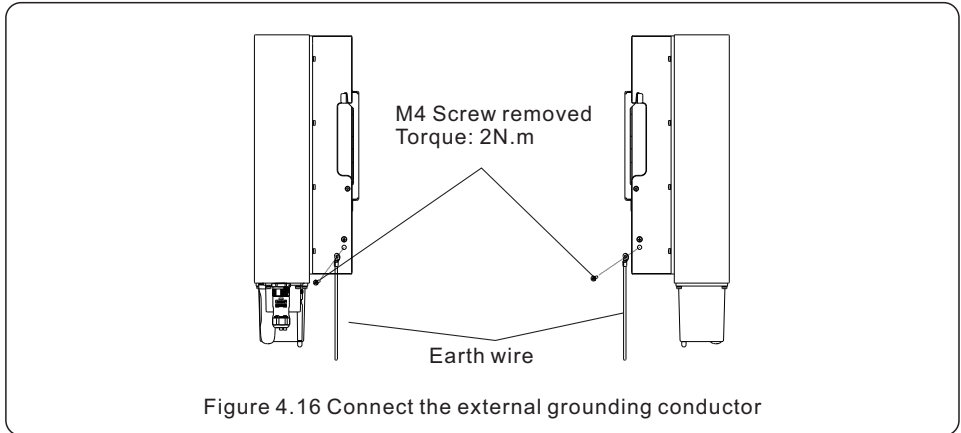

To connect the grounding terminal on the heat sink, please follow the steps below:

1. It is recommended to use copper wire for the chassis ground. Either solid conductor or stranded wire is acceptable. Refer to local code standard for wire sizing.
2. Attach OT terminal: M4.



IMPORTANT

For multiple inverters in parallel, all inverters should be connected to the same ground point to eliminate the possibility of a voltage potential existing between inverter grounds.

3. Strip the ground cable insulation to a suitable length. (see Figure 4.17)
4. Crimp a ring connector onto the cable and then connect it to the chassis ground terminal.

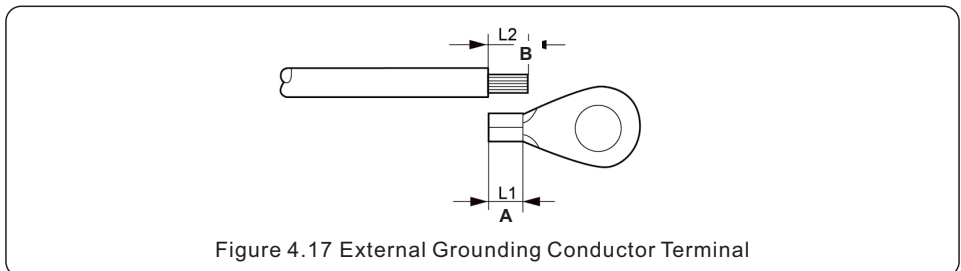

5. The external grounding conductor is recommended to be connected to 4mm² and above.

4.8 Meter/CT Installation

S6-EA1P(3.6-6)K-L inverter requires a smart meter to measure the power flow at the grid connection point to achieve the self-use control algorithm. The smart meter and the communication cable are provided as a standard accessory in the package. Please refer to below system diagram to connect the smart meter at the grid connection point. Meanwhile, a smart CT sensor is provided in order to measure the generation of grid-tied PV inverter.

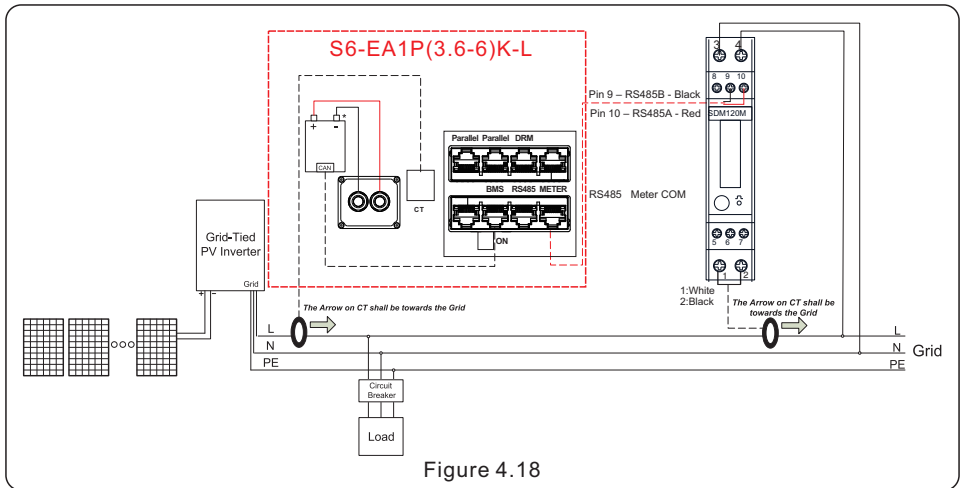

Smart Meter for grid power flow measurement (External CT provided within the meter package).

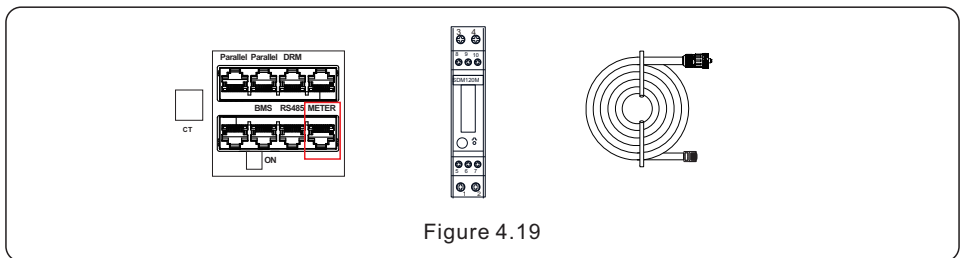

Smart CT sensor for PV generation measurement.

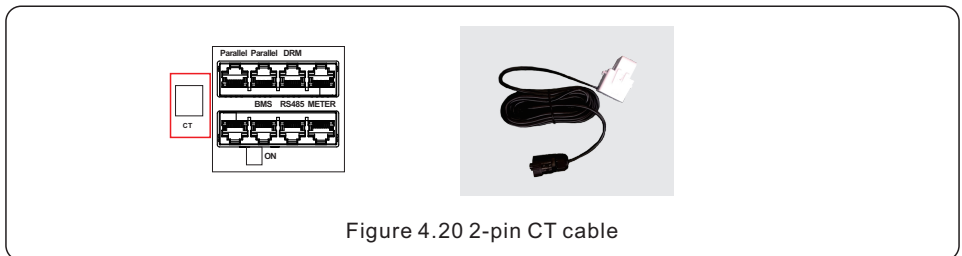

4.9 Communication Cable Installation

4.9.1 Protective Cover for Communication Ports

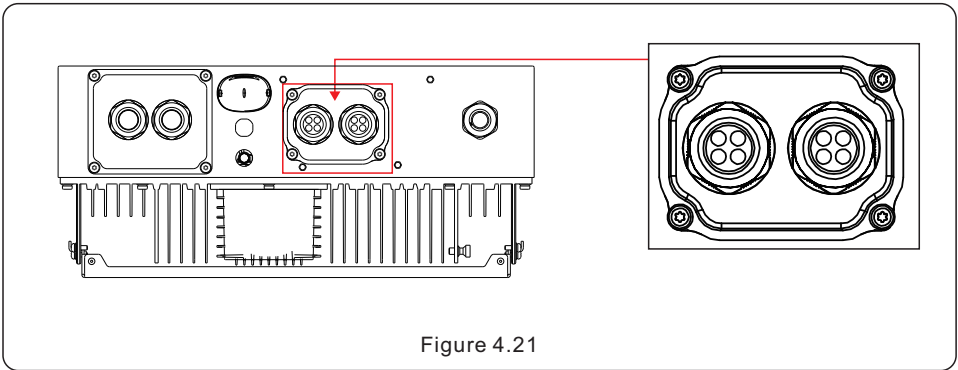

Inverter in the package is with a protective cover assembled to protect the communication ports.

Step 1. Use Phillips screwdriver to take out the 4 screws on the cover.

Step 2. Read through the following sections of the manual and prepare the internet cables correspondingly.

Step 3. Loose the cable gland and remove the watertight caps inside the cable gland based on the number of the cables and keep the unused holes with watertight cap.

Step 4. Lead the cables into the holes in the cable gland. (Hole Diameter: 6mm)

Step 5. Crimp the RJ45 connectors onto the cables according to the pin definitions described in the following sections and connect to the ports accordingly.

Step 6. Fasten the 4 screws on the cover (Torque: 1.7N.m-2 N.m)

Step 7. Reassemble the cable gland and ensure there is no bending or stretching of the internet cables inside the cover.



NOTE:

The 4-hole fastening rings inside the cable gland are with openings on the side. Please separate the gap with hand and squeeze the cables into the holes from the side openings.

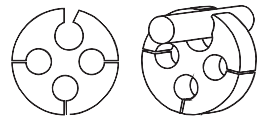

4.9.2 Communication Port Definition

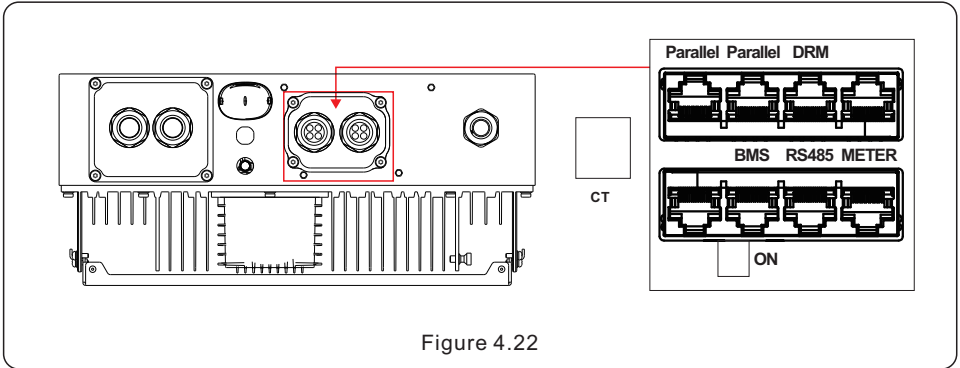

Figure 4.22

Port	Function
Parallel	(Optional) Parallel operation communication ports (Reserved).
DRM	(Optional) To realize Demand Response or Logic interface function, this function may be required in UK and Australia.
BMS	Used for CAN communication between inverter and Lithium battery BMS.
RS485	(Optional) Used for Modbus RTU communication with 3rd party external device or controller.
Meter	Used for RS485 communication between inverter and the smart meter. It is necessary to realize the normal hybrid control logics.

Table 4.3

4.9.3 BMS Port Connection

Take out the pre-made CAN cable from the package and connect one end to battery CAN port and then connect another end to the inverter BMS port. Cable Length: 3 meters.



Figure 4.23



NOTE:

Before connecting CAN cable with the battery, please check whether the communication pin sequence of the inverter and the battery match; If it does not match, you need to cut off the RJ45 connector at one end of the CAN cable and adjust the pin sequence according to the pin definitions of both inverter and battery.

Pin definition of the inverter CAN Port is following EIA/TIA 568B.

CAN-H on Pin 4: Blue

CAN-L on Pin 5: Blue/White

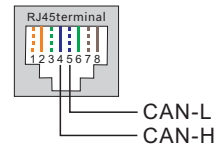

4.9.4 Battery Temperature Sensor Connection for Lead-acid Battery (Optional)



NOTE:

Battery temperature sensor can be optionally used with lead-acid battery for inverters to accurately detect the battery ambient temperature and adjust voltage compensation based on the customer-defined coefficient. It is an optional accessory which may not be provided with the inverter package. If lead-acid battery is used and battery temperature sensor is needed, please contact your distributor or Solis sales to purchase individually.

1. Insert the RJ45 terminal end to the CAN port at the bottom of the inverter and fasten the swivel nut. (Cable length: 1 meter)
2. Fasten the temperature sensor ring onto the battery module. If no suitable fastening terminal can be found on the battery module, the sensor ring can be attached to the positive or negative pole of the battery module.

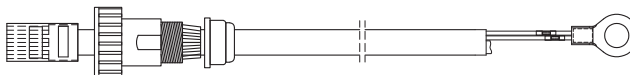

Figure 4.24

4.9.5 Meter Port Connection

Take out the pre-made Meter cable from the package and connect RJ45 end to inverter Meter port and then connect another end with loose RS485 A & B pins to the meter RS485 terminal. Cable Length: 5 meters.

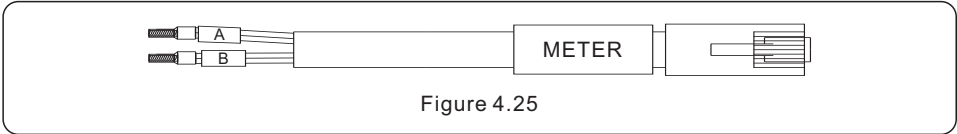

Figure 4.25

NOTE:
Pin definition of the Meter Port is following EIA/TIA 568B.
RS485A on Pin 1: Orange/white
RS485B on Pin 2: Orange

NOTE:
Compatible Smart Meter Pin definition.
Eastron SDM120CT – Pin 9 is RS485B & Pin 10 is RS485A.

4.9.6 DRM Port Connection (Optional)

4.9.6.1 For Remote Shutdown Function

Solis inverters support remote shutdown function to remotely control the inverter to power on and off through logic signals.

The DRM port is provided with an RJ45 terminal and its Pin5 and Pin6 can be used for remote shutdown function.

Signal	Function
Short Pin5 and Pin6	Inverter Generates
Open Pin5 and Pin6	Inverter Shutdown in 5s

Table 4.4

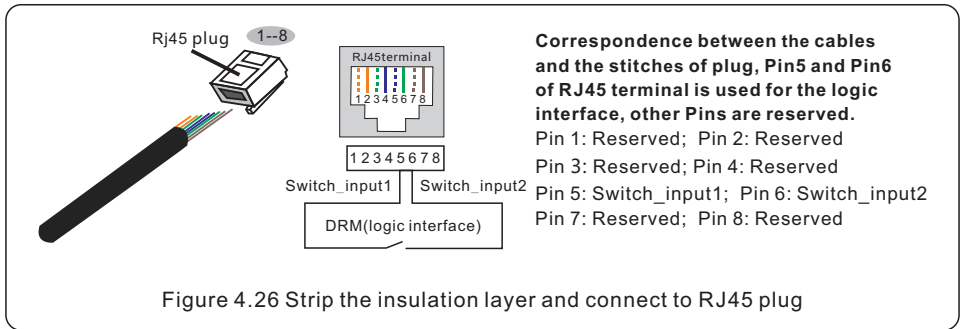

4.9.6.2 For DRED Control Function (For AU and NZ Only)

DRED means demand response enable device. The AS/NZS 4777.2:2020 required inverter need to support demand response mode(DRM).

This function is for inverter that comply with AS/NZS 4777.2:2020 standard.

A RJ45 terminal is used for DRM connection.

Pin	Assignment for inverters capable of both charging and discharging	Pin	Assignment for inverters capable of both charging and discharging
1	DRM 1/5	5	RefGen
2	DRM 2/6	6	Com/DRM0
3	DRM 3/7	7	V+
4	DRM 4/8	8	V-

Table 4.4



NOTE:

Solis hybrid inverter is designed to provide 12V power for DRED.

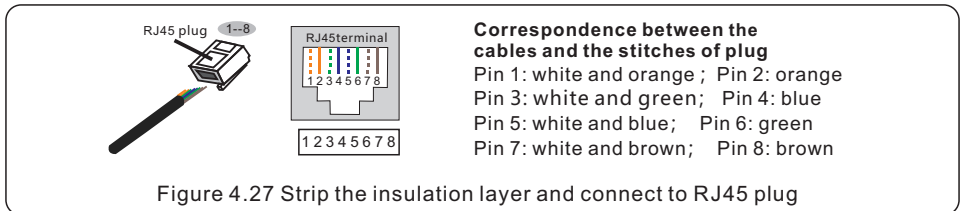

4.9.7 RS485 Port Connection (Optional)

If a 3rd party external device or controller needs to communicate with the inverter, the RS485 port can be used. Modbus RTU protocol is supported by Solis inverters.

To acquire latest protocol document, please contact Solis local service team or Solis sales.



NOTE:

Pin definition of the RS485 Port is following EIA/TIA 568B.

RS485A on Pin 3:Green/White

RS485B on Pin 2:Orange

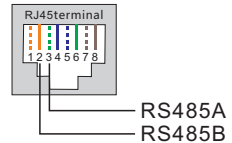

4.10 External Residual Current Device(RCD)

All series of Solis inverters are integrated with an internal residual current device to protect against any potential d.c component and a.c component of residual current.

Therefore, all Solis inverters, due to the design, are not able to feed in DC fault current to the system which fully complies with IEC60364-7-712.

If an external RCD is required to be installed by local regulations, Solis recommends installing a Type-A RCD with a threshold current higher than 100mA.

4.11 Earth Fault Alarm

For the earth fault happened on battery inputs, customer shall install external alarm and monitoring device to comply with AS/NZS 5139.

4.12 Inverter Remote Monitoring Connection

The inverter can be remotely monitored via WiFi, LAN or 4G.

The USB type COM port at the bottom of the inverter can connect to different kinds of Solis data loggers to realize the remote monitoring on Soliscloud platform.

To install Solis data loggers, please refer to corresponding user manuals of Solis data loggers.

The Solis data loggers are optional and can be purchased separately.

Dust cover is provided the inverter package in case the port is not used.



WARNING:

The USB type COM port is only allowed to connect Solis data loggers. It is forbidden to be used for other purposes.

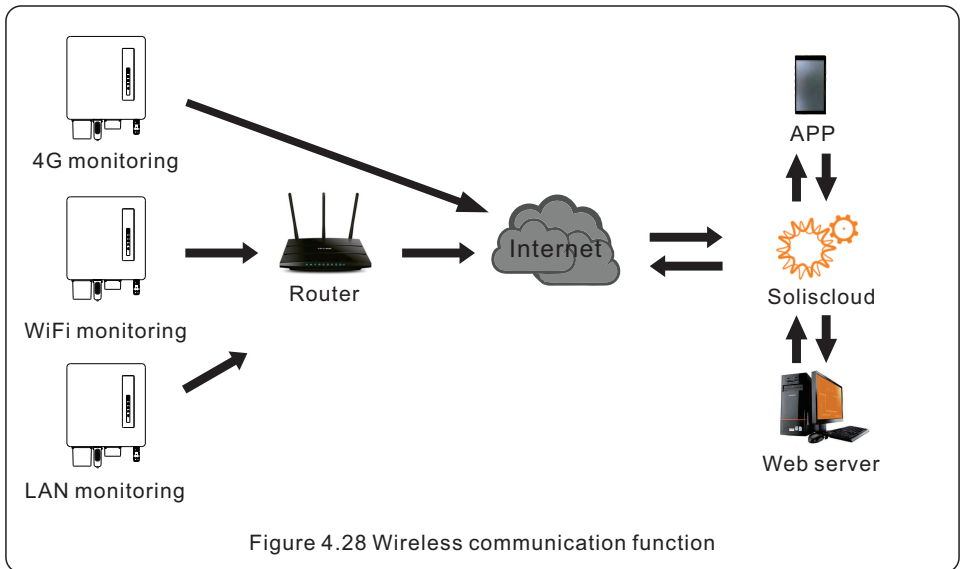
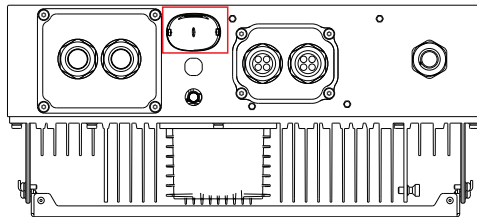

4.13 System Diagram

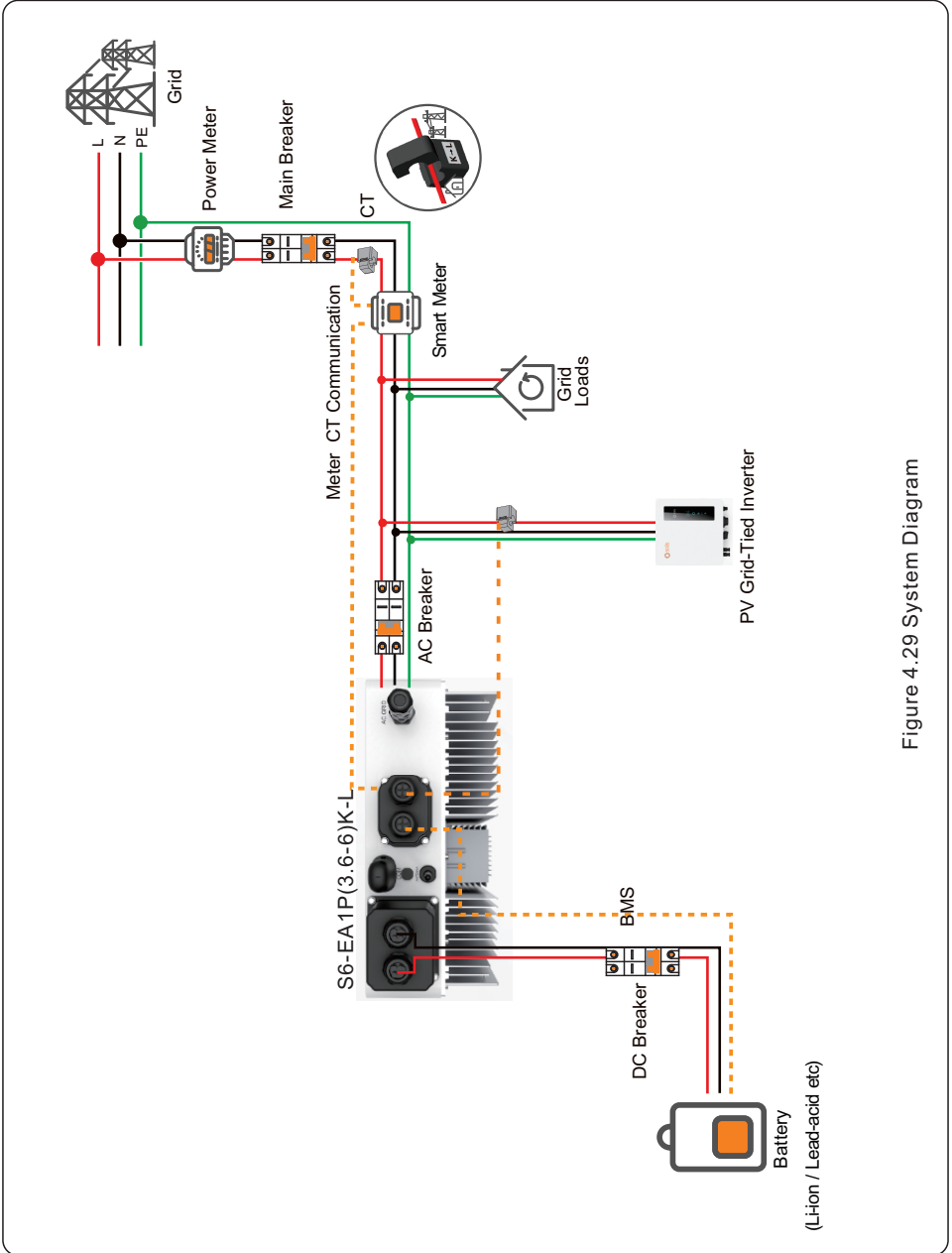

5.1 Pre-Commissioning

- Make sure that no high voltage conductors are energized.
- Check all conduit and cable connection points ensure they are tight.
- Verify that all system components have adequate space for ventilation.
- Follow each cable to ensure that they are all terminated in the proper places.
- Ensure that all warning signs and labels are affixed on the system equipment.
- Verify that the inverter is secured to the wall and is not loose or wobbly.
- Prepare a multimeter that can do both AC and DC amps.
- Have an Android or Apple mobile phone with Bluetooth capability.
- Install the Soliscloud APP on the mobile phone and register a new account.
- There are three ways to download and install the latest APP.
 - 1.You can visit www.soliscloud.com.
 - 2.You can search"Soliscloud" in Google Play or APP Store.
 - 3.You can scan this QR code to download Soliscloud.



5.2 Startup Procedure

- Step 1: Measure and confirm the battery polarity and battery voltage.
- Step 2: Measure and confirm the AC voltage and polarity.
- Step 3: Turn on the external battery breaker or the DC switch on the battery and then turn on the AC breaker.
- Step 4: Wait for the inverter to initialize

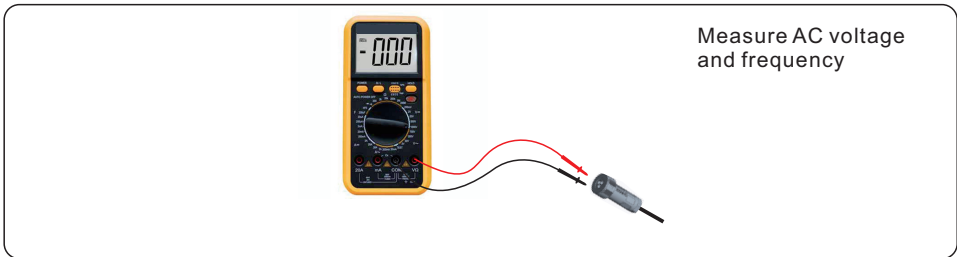

5.3 Shutdown Procedure

- Step 1: Turn off the AC breaker or AC disconnect switch to disable AC power to the inverter.
- Step 2: Turn off the battery breaker.
- Step 3: Use a multimeter to verify that the battery and AC voltages are 0V.
- Step 4. Waiting for the device powered off and the system shutdown is completed.

5.4 Log in the APP via Bluetooth

Step 1: Connect with Bluetooth.

Turn on Bluetooth switch on your mobile phone and then open the Soliscloud APP. Click "More Tools"->"Local Operation"->"Connect with Bluetooth"

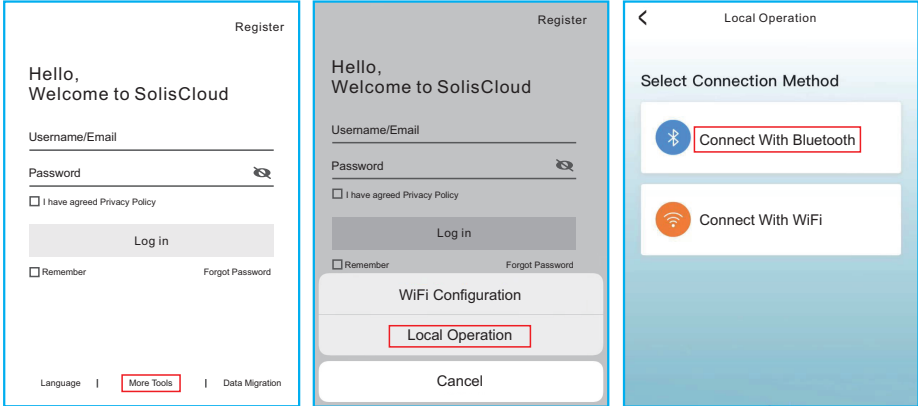

Step 2: Select the Bluetooth signal from the inverter. (Bluetooth Name: Inverter SN)

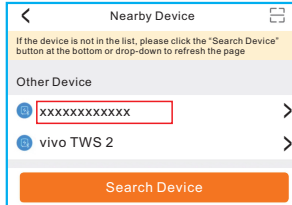

Step 3: Login account.

If you are the installer, please select the account type as Installer. If you are the plant owner, please select the account type as owner. Then set your own initial password for control verification. (The first log-in must be finished by installer in order to do the initial set up)

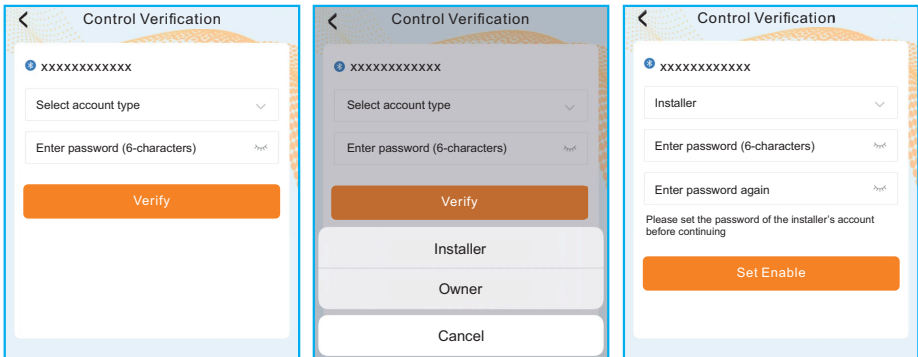

5.5 Initial set up

If this is the first time the inverter has been commissioned, you will need to first go through the Quick Settings. Once this has been done, these settings can be changed later.

Inverter Time -> Battery Model -> Meter Setting -> Grid Code -> Work mode

A. Inverter Time: Set the Inverter Time and Date. It may be easier to tap the slider next to "Follow Phone Time". Then tap Next in the top right corner. This will set the inverter to match your phone.

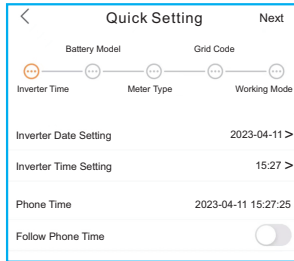

B. Battery Model: Now select the battery model connected to the inverter. This choice must be based on the battery model that is actually connected to the inverter. If there is no battery connected for the moment, select "No Battery" to avoid potential alarms codes.

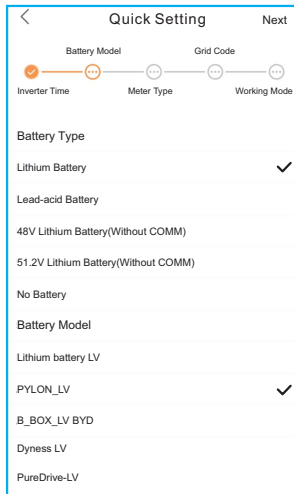

C. Meter Setting: Set both the Meter Type and the Meter Location. It is suggested to install the meter at the system grid connection point and select “Meter in Grid”. If there is no meter connected for the moment, please select “No Meter” to avoid alarms.

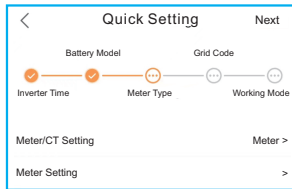

D. Grid Code: Please select the grid code based on the local grid network requirements.

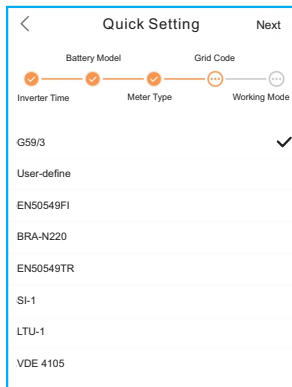

E. Work Mode: This is the energy storage operating mode. ALL modes first priority is to use the available PV power to support the home loads. The different modes determine what the second priority, or use of the excess PV power, will be. Select the desired mode, then tap the slider switch to turn the mode on. The switch will appear orange if it is enabled.

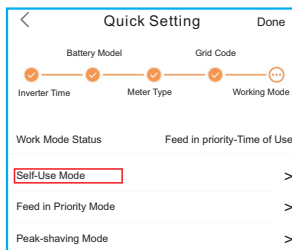

Self-Use Mode stores the excess PV power into the battery. If the battery is charged, or there is no battery, the excess PV power will be exported(sold)back to the utility company.

Feed in Priority Mode will ensure that the system exports any excess PV power after the home loads are supplied. If the export power quota has been met, then the remaining PV power will be stored in the battery. This mode should not be used if export power is going to be set to zero.

Peak-shaving Mode limits the power of grid and the battery discharging. With this working mode, the inverter will discharge the battery only when the power consumption from the grid will be over a certain value, set by the user. The discharge of the battery will be stop any time the power absorption from grid will be lower than the value set.

Time of Use Switch is for customizing when the battery is allowed to charge and discharge power and at what rate, established by a current(amperage)setting. If this slider switch is turned on, the inverter will only use this schedule to determine when to charge and discharge the battery.

If Allow Grid Charging is turned on, the inverter will use grid power to charge the battery only under two circumstances:

- (1) the battery drains to the Force Charge SOC.
- (2)Time of Use is enabled and there is not enough available PV power during the charge window to meet the current rate that is established.

Time of Use is for manual control of the battery charging/discharging. If Time of Use is turned off, charging/discharging is automatically regulated by the inverter.



NOTE:

PV Power input is not integral for the S6-EA1P(3.6-6)K-L inverter series.

< Self-Use Mode

Self-Use Mode Switch

Time of Use Switch

Time of Use Charge Current Set 50.0A >

Time of Use Discharge Current Set 50.0A >

Charge Time Slot 1 22:00 ~ 08:00 >

Discharge Time Slot 1 08:00 ~ 22:00 >

Charge Time Slot 2 00:00 ~ 00:00 >

Discharge Time Slot 2 00:00 ~ 00:00 >

Charge Time Slot 3 00:00 ~ 00:00 >

Discharge Time Slot 3 00:00 ~ 00:00 >

Charge Time Slot 4 00:00 ~ 00:00 >

Discharge Time Slot 4 00:00 ~ 00:00 >

Charge Time Slot 5 00:00 ~ 00:00 >

Discharge Time Slot 5 00:00 ~ 00:00 >

Charge Time Slot 6 00:00 ~ 00:00 >

Discharge Time Slot 6 00:00 ~ 00:00 >

Allow Grid Charging

< Feed in Priority Mode

Feed in Priority Mode Switch

Time of Use Switch

Time of Use Charge Current Set 135.0A >

Time of Use Discharge Current Set 135.0A >

Charge Time Slot 1 00:00 ~ 01:00 >

Discharge Time Slot 1 01:00 ~ 02:00 >

Charge Time Slot 2 02:00 ~ 04:00 >

Discharge Time Slot 2 04:00 ~ 06:00 >

Charge Time Slot 3 06:00 ~ 10:00 >

Discharge Time Slot 3 10:00 ~ 11:00 >

Charge Time Slot 4 11:00 ~ 14:00 >

Discharge Time Slot 4 14:00 ~ 17:00 >

Charge Time Slot 5 17:30 ~ 18:00 >

Discharge Time Slot 5 18:00 ~ 22:55 >

Charge Time Slot 6 23:00 ~ 23:30 >

Discharge Time Slot 6 23:30 ~ 00:00 >

Allow Grid Charging

< Peak Shaving

Peak-shaving switch

Max.useable Grid Power 3000W >

Peak SOC 70% >

Time of Use Switch

Time of Use Charge Current Set 50.0A >

Time of Use Discharge Current Set 50.0A >

Charge Time Slot 1 22:00 ~ 08:00 >

Discharge Time Slot 1 08:00 ~ 22:00 >

Charge Time Slot 2 00:00 ~ 00:00 >

Discharge Time Slot 2 00:00 ~ 00:00 >

Charge Time Slot 3 00:00 ~ 00:00 >

Discharge Time Slot 3 00:00 ~ 00:00 >

Charge Time Slot 4 00:00 ~ 00:00 >

Discharge Time Slot 4 00:00 ~ 00:00 >

Charge Time Slot 5 00:00 ~ 00:00 >

Discharge Time Slot 5 00:00 ~ 00:00 >

Charge Time Slot 6 00:00 ~ 00:00 >

Discharge Time Slot 6 00:00 ~ 00:00 >

Allow Grid Charging

5.6 APP Interface

5.6.1 APP Interface Structure

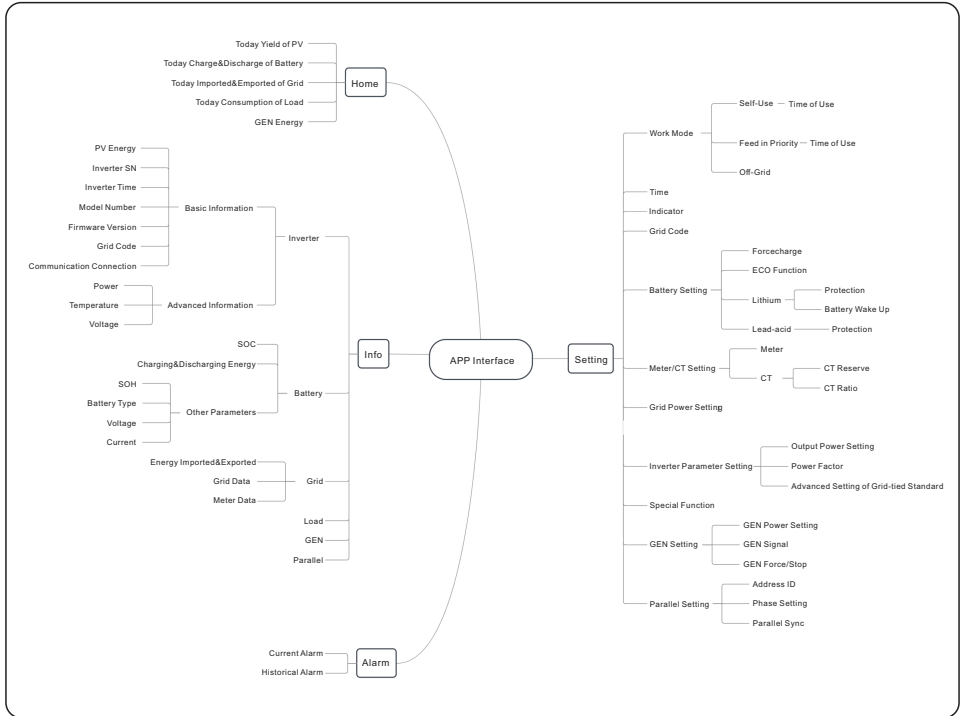

5.6.2 Home

The home page can display the working state, Today Imported/Exported of Grid, Today Charged /Discharged of Battery , Today Consumption of household electricity. At the bottom of page are four submenus: Home, Info, Alarm and Settings.

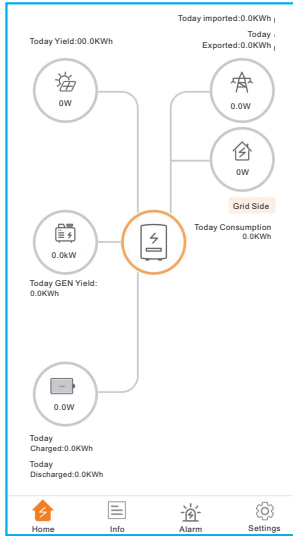

5.6.3 Information

The Info page breaks down into four categories: Inverter, Battery, Grid, and Load.

Inverter: inverter power production history, PV voltages and currents, inverter information (serial number, model number, and firmware version), grid code, and alarm code history.

There are two additional information in the inverter page:

Parallel Information: information includes inverter, battery, grid and load.

Battery: battery model and status, battery voltage and current.

Grid: power imported an exported, AC grid voltage, frequency, and amperage.

Load: power being consumed by the home loads.

<u>Inverter</u>	Battery	Grid	Load
Total Yield		221kWh	
14.2kWh	191kWh	221kWh	
Today Yield	This Month Yield	This Year Yield	
12.8kWh	30kWh	0kWh	
Yesterday Yield	Last Month Yield	Last Year Yield	
View Historical Yield >			
Total PV Input Power		865W	
	Voltage	Current	Power
Pv1	432.6V	2.0A	865.20W
Pv2	0.0V	0.0A	0.00W
Inverter SN	103115022B100041		
Inverter Time	2022-12-23 15:32:03		
Rated Power	6kW		
Model Number	3115		
DSP Firmware Version	V2		
HMI Firmware Version	V1		
HMI Firmware Subversion	Vd		
Grid Code	G59/3		
Communication Connection	>		
Advanced Information	>		

Inverter	<u>Battery</u>	Grid	Load
49W Discharge Power	99% Battery SOC		
	Charged	Discharged	
Today	6.8kWh	0.2kWh	
Total	1830kWh	1536kWh	
Other Parameters(From BMS)			
Battery SOH	100%		
Battery Model	Dyness LV		
BMS Status	Normal		
Battery Voltage BMS	50.28V		
Battery Current BMS	0.0A		
BMS Charge Current Limit	10.0A		
BMS Discharge Current Limit	75.0A		
Other Parameters(From inverter)			
Battery Voltage	49.8V		
Battery Current	1.0A		
OverVoltage Protection Value	60.0V		
UnderVoltage Protection Value	42.0V		
Battery Equalization Voltage	53.5V		

Inverter	Battery	<u>Grid</u>	Load
	Exported	Imported	
Today	0.0kWh	0.0kWh	
Yesterday	0.0kWh	0.0kWh	
Total	1kWh	0kWh	
Grid Data			
Power	-1399W		
Voltage	220.8V		
Frequency	49.95Hz		

Inverter	Battery	Grid	<u>Load</u>
Grid Side			
Grid Load Power(Active)			0W
Total Grid Load Consumption			0kWh
Today Grid Load Consumption			0.0kWh
This Month Grid Load Consumption			0kWh
This Year Grid Load Consumption			0kWh

5.6.4 Alarm

The alarm page can display the current alarm and the historical alarm.

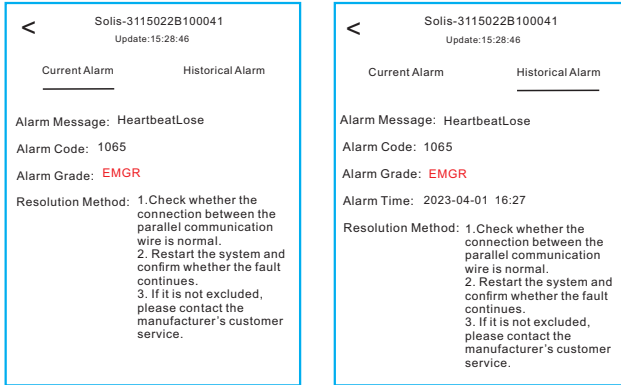

5.6.5 Settings

Mode Setting

The interface can display the current work mode, Self-Use/Feed in Priority/Off-Grid. Please refer to page xxx for specific introduction.

Battery Setting

Battery Model: select the battery model to be connected.

Peak-shaving setting: If the switch is enable, the power of force charging will be dynamically adjusted.

Five samples to be clear: (Forcecharge Limited Power Setting=4kW)

If the load=3kW,PV=0kW,P_forcecharge=P_Grid(4kW)-P_Load(3kW)=1kW.

If the load=10kW,PV=0kW,P_forcecharge=0kW,P_Grid=P_Load=10kW.

ECO Function: If PV power is lower than 100W and SOC falls below overdischarge SOC, the inverter will turn off the grid relays and IGBT switching. If forcecharge SOC is reached, it will connect back to grid and charge battery back to overdischarge SOC, then turn off again.

Battery wake up: After Battery wake up command, the inverter powers the DC battery port using Battery Wakeup Voltage and low AMP till BMS communication of battery will be restored and within awaken time.

Over-discharge SOC: When the battery is discharged to the over-discharge soc, the battery will nor discharge actively.(Due to the internal current, conduction, there is a small self-consumption power, if not charged for a long time, the SOC will slowly continue to decline.)

Force-charge SOC: Due to the battery power consumption, when the over-discharge SOC drops to the force-charge SOC, the inverter will directly charge the battery according to the maximum battery charging current until the battery SOC reaches the over-discharge SOC. (The charging power is not limited to sources, which may be from PV or from the grid. If “Charging from grid” is set to “Not Allow”, the charging logic may not be implemented.) It is not recommended to set the over-discharge & force-charge SOC to the same value, which may cause frequent charging and discharging.

Battery Setting	
Battery Model	PYLON_LV >
Peak-shaving Setting	<input type="checkbox"/>
Max. grid power when Forcecharging	500W >
Max. grid power when Forcecharging (Parallel)	0W >
ECO Function	<input type="checkbox"/>
Overdischarge SOC	20% >
Forcecharge SOC	10% >
Battery Overvoltage Protection Setting	60.0V >
Battery Undervoltage Protection Setting	42.0V >
GEN_Start_SOC	25% >
GEN_Exit_SOC	80% >
Battery Wake Up	>
Awaken Voltage	40.0V >
Awaken Time	20s >

Battery Setting	
Battery Model	Lead Acid >
Peak-shaving Setting	<input type="checkbox"/>
Max. grid power when Forcecharging	500W >
Max. grid power when Forcecharging (Parallel)	0W >
ECO Function	<input type="checkbox"/>
Battery Capacity	200Ah >
Max Charging Current	100.0A >
Max Discharging Current	100.0A >
Battery Overvoltage Protection Setting	60.0V >
Battery Undervoltage Protection Setting	42.0V >
Overdischarge Voltage	44.5V >
Force Voltage	43.8V >
GEN_Start_Volt	48.5V >
GEN_Exit_Volt	52.0V >
Equalization Voltage	56.4V >
Lead Acid TEMP CO	72mV/°C >
Environment temperature	Normal temper... >

Meter/CT Setting

You can select meter or CT for system measurement.

Meter Type: Please select a correct type. The wrong option may cause the meter RS485 communication Failed. If the battery and meter are not connected, please select the “NO Meter” to shield the alarm of meter communication fault.

CT Reverse: If the direction is wrong, the sampling current of CT will be reversed when calculating the power.

CT Ratio: CT ratio is adjustable.

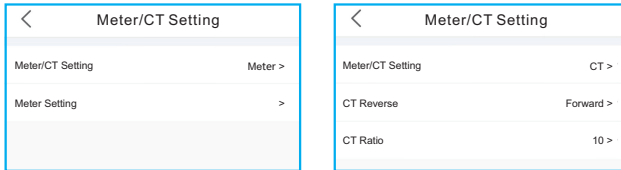

Grid Power Setting

System Export Power/Current: This is the amount of power/current the inverter is permitted to export(or sell) back to the utility company. If you do not want the system exporting power, this setting must be configured.

Failsafe Switch: Enabling the Failsafe switch will mean that the inverter will not produce any P power if the inverter loses communication with the meter.

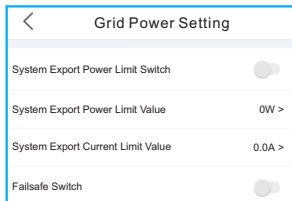

Parallel Setting

Parallel Mode: Single/Parallel

Address ID: 1 to 6

Manual Set Master/Slave: Address ID 1 is Master, the others is Slave.

Inverter Connected Phase Setting: Single Phase(single phase system)/
Phase A(Three Phase)/Phase B(Three Phase)/Phase C(Three Phase)

Total number of hybrid inverters connected: 0-6

Parallel Sync: The parameters of the master will be synchronized to the slaves, and some parameters of the slave cannot be set.

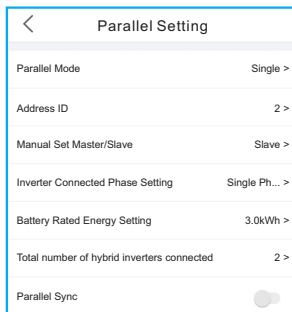

The inverter commissioning process has now been completed. It is recommended to monitor the system closely over the next week to ensure that everything is working as it should. Please refer to the Solis data logger manual for assistance with registering a new plant on SolisCloud.



NOTE:

A full factory reset can be done, if needed. This function can be found in the Special Setting Function menu within the Settings tab.

5.7 Australian Grid Code Settings

Customers can follow the quick setting process to select the corresponding grid codes based on AS/NZS 4777.2:2020 Amd 2:2024 (4777-A/ 4777-B/ 4777-C/ 4777-N).

Or modify the grid code in following path in the APP: Settings -> Grid Code Setting

NOTE:



The standard code selection “4777-A”, “4777-B”, “4777-C” and “4777-N” already have preset default settings as required by AS/NZS 4777.2:2020 Amd 2:2024. Unless specially required, customers do not need to gain access to the following sections or modify any settings inside. When “4777-C” is selected, the upper connection and reconnection frequency(fURF), is 50.50 Hz.

Region	Australia A	Australia B	Australia C	New Zealand	
Standard Code Name	4777-A	4777-B	4777-C	4777-N	Setting Range
OV-G-V1	265V	265V	265V	265V	230-276V
OVG1-T	1.5S	1.5S	1.5S	1.5S	1-2S
OV-G-V2	275V	275V	275V	275V	230-276V
OVG2-T	0.1S	0.1S	0.1S	0.1S	0.1-2S
UN-G-V1	180V	180V	180V	180V	38-230V
UNGV1-T	10S	10S	10S	10S	10-11S
UN-G-V2	70V	70V	70V	70V	38-230V
UNGV2-T	1.5S	1.5S	1.5S	1.5S	1-2S
OV-G-F1	52HZ	52HZ	55HZ	55HZ	50-55HZ
OVG1-T	0.1S	0.1S	0.1S	0.1S	0.1-2S
OV-G-F2	52HZ	52HZ	55HZ	55HZ	50-55HZ
OVG2-T	0.1S	0.1S	0.1S	0.1S	0.1-2S
UN-G-F1	47HZ	47HZ	45HZ	45HZ	45-50HZ
UNGF1-T	1.5S	1.5S	5S	1.5S	1-6S
UN-G-F2	47HZ	47HZ	45HZ	45HZ	45-50HZ
UNGF2-T	1.5S	1.5S	5S	1.5S	1-6S
Startup-T	60S	60S	60S	60S	10-600S
Restore-T	60S	60S	60S	60S	10-600S
Recover-VH	253V	253V	253V	253V	230-276V
Recover-VL	205V	205V	205V	196V	115-230V
Recover-FH	50.15Hz	50.15Hz	50.50Hz	50.15Hz	50-52Hz
Recover-FL	47.5Hz	47.5Hz	47.5Hz	47.5Hz	47-50Hz
Start-VH	253V	253V	253V	253V	230-276V
Start-VL	205V	205V	205V	196V	115-230V
Start-FH	50.15Hz	50.15Hz	50.50Hz	50.15Hz	50-52Hz
Start-FL	47.5Hz	47.5Hz	47.5Hz	47.5Hz	47-50Hz

5.7.1 Working Mode Set

Solis AU version inverters have the following working mode settings:

1. Null
2. Volt-Watt
3. Volt-Var
4. Fixed PF
5. Fixed Reactive

The setting path in the APP is: Settings-> Inverter Parameter Setting -> Advanced Setting of Grid Code -> Work Mode Setting

1. NULL

Description: Inverter will not be under any working mode.

2. Volt-Watt

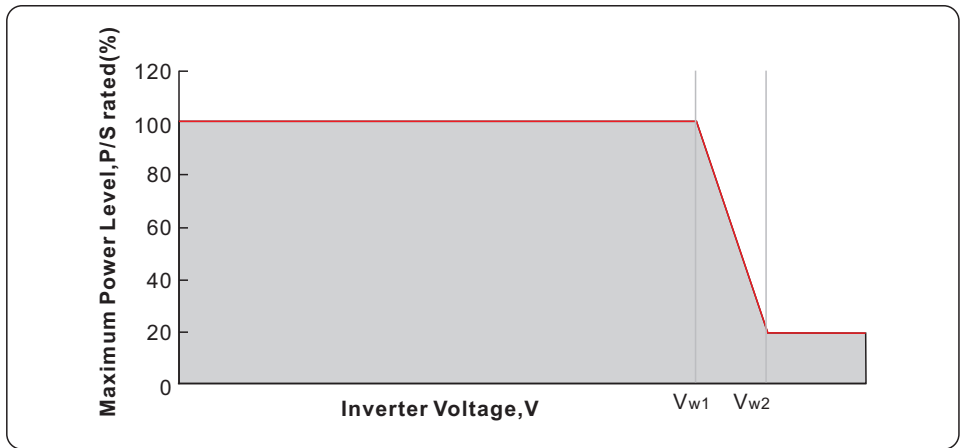

Status: Enable/Disable (Note: This is used to enable or disable the Volt-Watt mode)

Voltage 1: 207V

P-Limit 1: 100%

Voltage 2: 220V

P-Limit 2: 100%

Voltage 3 (V_{w1}):

235-255V (Default: 4777-A(253V); 4777-B(250V);4777-C(253V);4777-N(242V))

P-Limit 3: 100%

Voltage 4 (V_{w2}):

240-265V (Default: 4777-A(260V); 4777-B(260V);4777-C(260V);4777-N(250V))

P-Limit 4: 0%-20% (Default: 20% for 4777-A; 4777-B; 4777-C; 4777-N)

3. Volt-Var

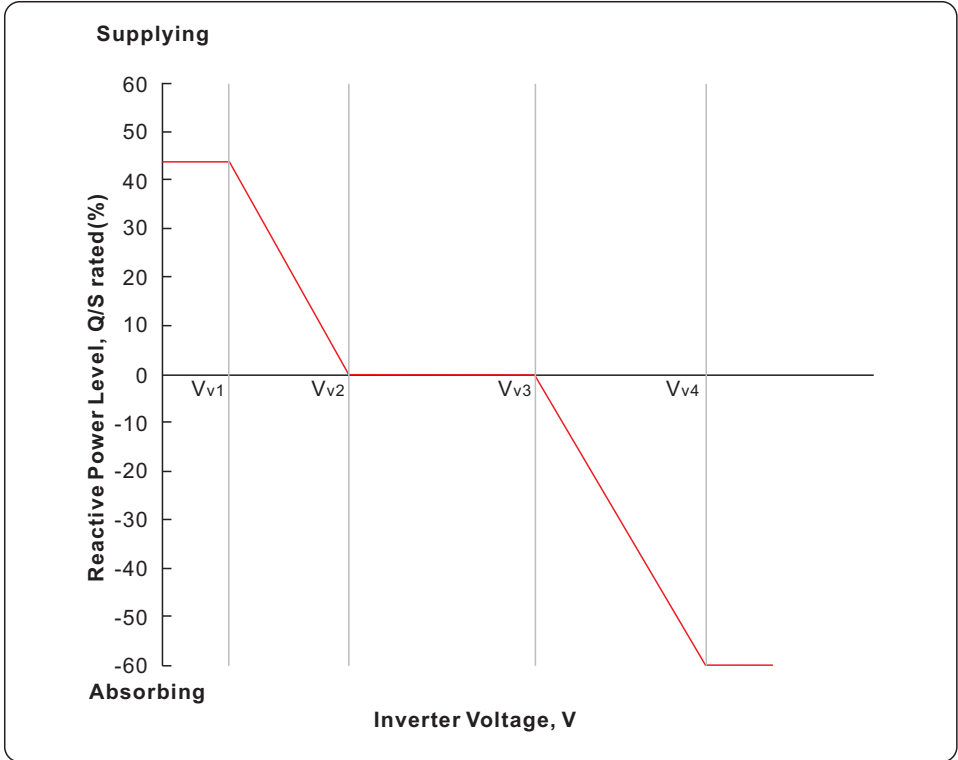

Voltage 1 (Vv1):

180-230V (Default: 4777-A(207V); 4777-B(205V);4777-C(215V);4777-N(207V))

Voltage 2(Vv2) :

180-230V (Default: 4777-A(220V); 4777-B(220V);4777-C(230V);4777-N(220V))

Voltage 3(Vv3) :

230-265V (Default: 4777-A(240V); 4777-B(235V);4777-C(240V);4777-N(235V))

Voltage 4(Vv4) :

230-265V (Default: 4777-A(258V); 4777-B(255V);4777-C(255V);4777-N(244V))

Leading(Supplying) :

+30~+60% (Default: 4777-A(+44%); 4777-B(+30%);4777-C(+44%);4777-N(+60%))

Lagging(Absorbing) :

-30%~-60% (Default: 4777-A(-60%); 4777-B(-40%);4777-C(-60%);4777-N(-60%))

4. Fixed PF

Description: This mode is to set a fixed power factor output

Range: -0.8~+0.8

Default: 1

5. Fixed Reactive

Description: This mode is to set a fixed reactive power output

Range:-60%~+60%

Default: 0%

5.7.2 Power Rate Limit

Settings-> Inverter Parameter Setting -> Advanced Setting of Grid Code->Power Limit

To set the power rate limits for increase and decrease in power level per minute.

Wgra+: 5-100%, Default:16%

Wgra-: 5-100%, Default:16%

5.7.3 Freq Derate Set

Settings-> Inverter Parameter Setting -> Advanced Setting of Grid Code->

Frequency Derating Setting

To set the frequency response limits for response to a decrease/increase in frequency.

OVF_Start(F_ULCO): 50.1Hz~50.5Hz

(Default: 4777-A(50.25Hz), 4777-B(50.15Hz), 4777-C(50.5Hz), 4777-N(50.2Hz))

OVF_Stop(F_Pmin): 51Hz~53Hz

(Default: 4777-A(52Hz), 4777-B(52Hz), 4777-C(53Hz), 4777-N(52Hz))

UNF_Start(F_LLCO): 49.5Hz~49.9Hz

(Default: 4777-A(49.75Hz), 4777-B(49.85Hz), 4777-C(49.5Hz), 4777-N(49.8Hz))

UNF_Stop(F_Pmax): 47Hz~49Hz

(Default: 4777-A(48Hz), 4777-B(48Hz), 4777-C(47Hz), 4777-N(48Hz))

5.7.4 10mins Voltage Set

Settings-> Inverter Parameter Setting -> Advanced Setting of Grid Code->Special Setting

-> 10min Overvoltage Setting

To set the 10mins average protection limit.

Range: 244V to 258V

Default: 4777-A (258V); 4777-B(258V); 4777-C(258V); 4777-N(249V)

5.7.5 DRM Settings

Settings-> Inverter Parameter Setting -> Advanced Setting of Grid Code->DRM Setting

"DRM ON/OFF" is used to enabled or disable the functionality of the DRM port.

5.8 Export Power Control

The export power control function is designed to comply with AS/NZS4777.2:2020. When customer select the grid code "4777-A", "4777-B", "4777-C", "4777-N", customer can find the export power control settings in the follow path on the APP: Settings-> System Export Power Setting.

Following parameters can be found on the APP and the functions are explained below:

Parameters	Functions	Setting Range
System Export Power Limit Switch	Enable/Disable the export power control function	ON/OFF
System Export Power Limit Value	The soft backflow power limit. Inverter will dynamically control the inverter output to meet the system export power limit	0~Inverter Max Output Power
System Export Power Hard Limit Switch	Enable/Disable the export power control hard limit	ON/OFF
System Export Power Hard Limit Value	The hard backflow power limit. If the System Export Power Hard Limit Switch is enabled and hard limit value is reached, inverter will shut down within 5s and give alarm as "EPM-Hard Limit"	0~Inverter Max Output Power

Solis S6 Series inverter does not require any regular maintenance. However, cleaning the heatsink will help the inverter dissipate heat and increase the lifetime of inverter. The dirt on the inverter can be cleaned with a soft brush.



CAUTION:

Do not touch the surface when the inverter is operating. Some parts may be hot and could cause burns. Turn OFF the inverter and let it cool down before you do any maintenance or cleaning of inverter.

The Screen and the LED status indicator lights can be cleaned with cloth if they are too dirty to be read.



NOTE:

Never use any solvents, abrasives, or corrosive materials to clean the inverter.

The inverter has been designed in accordance with international grid tied standards for safety, and electromagnetic compatibility requirements. Before delivering to the customer the inverter has been subjected to several tests to ensure its optimal operation and reliability.

In case of a failure the LCD screen will display an alarm message. In this case the inverter may stop feeding energy into the grid. The alarm descriptions and their corresponding alarm messages are listed in Table 7.1:

Alarm Message	Failure description	Solution
OV-G-V	Grid Overvoltage	Check if the grid is correctly connected, wait for the grid to be normal.
UN-G-V	Grid Undervoltage	Check if the grid is correctly connected, wait for the grid to be normal.
OV-G-F	Grid Overfrequency	Check if the grid is correctly connected, wait for the grid to be normal.
UN-G-F	Grid Underfrequency	Check if the grid is correctly connected, wait for the grid to be normal.
NO-Grid	No Grid	Check if the grid is correctly connected, wait for the grid to be normal.
OV-BUS	DC Bus overvoltage	Restart the inverter, if the fault still exists, contact Solis after-sale service.
UN-BUS	DC Bus voltage sampling Error	Restart the inverter, if the fault still exists, contact Solis after-sale service.
DC-INTF.	Battery Overcurrent	Restart the inverter, if the fault still exists, contact Solis after-sale service.
IGFOL-F	Grid Current Tracking Error	Restart the inverter, if the fault still exists, contact Solis after-sale service.
OV-G-I	Grid Overcurrent	Restart the inverter, if the fault still exists, contact Solis after-sale service.
AC Transient over current	AC Transient Overcurrent	Restart the inverter, if the fault still exists, contact Solis after-sale service.
DCInj-FAULT	Over DC injection	Restart the inverter, if the fault still exists, contact Solis after-sale service.
IGBT-OV-I	IGBT Overcurrent	Restart the inverter, if the fault still exists, contact Solis after-sale service.
OV-TEM	Internal Over Temperature	Check if the inverter installation meets the requirements listed in the manual, Restart the inverter, if the fault still exists, contact Solis after-sale service.
RelayChk-FAIL	Relay Fault	Restart the inverter, if the fault still exists, contact Solis after-sale service.

Alarm Message	Failure description	Solution
GRID-INTF02	Grid Interference 02	Restart the inverter, if the fault still exists, contact Solis after-sale service.
IG-AD	Grid Current Sampling Error	Restart the inverter, if the fault still exists, contact Solis after-sale service.
OV-IgTr	Grid Transient Overcurrent	Restart the inverter, if the fault still exists, contact Solis after-sale service.
OV-Vbatt-H	Battery Hardware Overvoltage	Check if the battery is correctly connected or the battery contactor is disconnected, Restart the battery, Restart the inverter, if the fault still exists, contact Solis after-sale service.
OV-ILLC	LLC Hardware Overcurrent	Restart the inverter, if the fault still exists, contact Solis after-sale service.
OV-Vbatt	Battery Overvoltage	Check if the battery overvoltage setting is reasonable, if the battery reaches its end of life.
UN-Vbatt	Battery Undervoltage	Check if the battery overvoltage setting is reasonable, if the battery reaches its end of life.
DSP-B-FAULT	Slave DSP Check Error	Restart the inverter, if the fault still exists, contact Solis after-sale service.
NO-Battery	Battery Not Connected	Check if the battery is correctly connected or the battery contactor is disconnected, Restart the battery.
CT-Fail	CT Installed Fail	Check if CT is correctly installed or the cables are broken/loosen .
MET_Comm_FAIL	Meter COM Fail	Check if the CT/Meter setting is correct or the cables are broken/loosen.
CAN_Comm_FAIL	Battery CAN Fail	Check if the CAN cable is correctly connected or the cables are broken/loosen.
DSP_Comm_FAIL	DSP COM Fail	Restart the inverter, if the fault still exists, contact Solis after-sale service.
Alarm-BMS	Battery BMS Alarm	Retart the battery, if fault still exists, please contact battery manufacturer or installer.
BatName-FAIL	Wrong Battery Model	Make sure the actual battery model matches the selection on inverter LCD.

Table 7.1 Fault message and description



NOTE:

If the inverter displays any alarm message as listed in Table 7.1; please turn off the inverter and wait for 5 minutes before restarting it. If the failure persists, please contact your local distributor or the service center.

Please keep ready with you the following information before contacting us.

1. Serial number of Solis Inverter;
2. The distributor/dealer of Solis Inverter (if available);
3. Installation date.
4. The description of problem (i.e. the alarm message displayed on the LCD and the status of the LED status indicator lights. Other readings obtained from the Information submenu will also be helpful.);
5. The system configuration.
6. Your contact details.

8. Specifications

Technical Data	S6-EA1P3.6K-L
Battery	
Battery type	Li-ion
Battery voltage range	40 - 60V
Max. charge power	3.6kW
Max. discharge power	3.9kW
Max. charge / discharge current	75A
Communication	CAN
Startup Voltage	40V
Output AC(Grid side)	
Rated output power	3.6kW
Max. apparent output power	3.6kVA
Operation phase	1/N/PE
Rated grid voltage	220 V/230 V
The grid voltage range	187-253 V
Rated grid frequency	50 Hz/60 Hz
AC grid frequency range	45-55 Hz/55-65 Hz
Rated grid output current	16.4 A/15.7 A
Max. output current	16.4 A/15.7 A
Inrush current	41.50A ,4.5ms
Max. output fault current	41.50A ,4.5ms
Max. output overcurrent protection	16.4 A
Power Factor	> 0.99 (0.8 leading - 0.8 lagging)
THDi	<3%
Input AC (Grid side)	
Input voltage range	187-253 V
Max. input current	16.4 A/15.7 A
Max. input power	3.6kW
Frequency range	45-55 Hz/55-65 Hz
Efficiency	
BAT charged/discharged to AC Max. efficiency	> 93.5%

8. Specifications

Technical Data	S6-EA1P3.6K-L
Protection	
Residual current monitoring	Yes
DC reverse polarity protection	Yes
Protection class / Over voltage category	I
Over voltage category	DC II, AC III
General data	
Dimensions(W/H/D)	440*465*192mm
Dimensions of package(W/H/D)	710*550*280mm
Weight	24.5kg
Topology	High frequency insulation
Operation temperature range	-25...+60°C
Relative humidity range	0-95%
Ingress protection	IP66
Cooling concept	Natural convection
Environmental category	Indoor and outdoor
Max.operation altitude	3000m
Active anti-islanding method	Active frequency shifting
Grid connection standard	C10/11, 50549, G98, G99, VDE4105, AS4777.2, France
Safety/EMC standard	IEC/EN 62109-1/-2, EN 61000-6-2/-3
Features	
Battery connection	Terminal Block
AC connection	Quick connection plug
Display	LED+APP
Communication	RS485,CAN, Optional: Wi-Fi, LAN
Warranty	5 years standard (extend to 20 years)

8. Specifications

Technical Data	S6-EA1P4.6K-L
Battery	
Battery type	Li-ion
Battery voltage range	40 - 60V
Max. charge power	4.6kW
Max. discharge power	4.9kW
Max. charge / discharge current	96A
Communication	CAN
Startup Voltage	40V
Output AC(Grid side)	
Rated output power	4.6kW
Max. apparent output power	4.6kVA
Operation phase	1/N/PE
Rated grid voltage	220 V/230 V
The grid voltage range	187-253 V
Rated grid frequency	50 Hz/60 Hz
AC grid frequency range	45-55 Hz/55-65 Hz
Rated grid output current	21.0 A/20.0 A
Max. output current	21.0 A/20.0 A
Inrush current	41.50A ,4.5ms
Max. output fault current	41.50A ,4.5ms
Max. output overcurrent protection	21.0 A
Power Factor	> 0.99 (0.8 leading - 0.8 lagging)
THDi	<3%
Input AC (Grid side)	
Input voltage range	187-253 V
Max. input current	21.0 A/20.0 A
Max. input power	4.6kW
Frequency range	45-55 Hz/55-65 Hz
Efficiency	
BAT charged/discharged to AC Max. efficiency	> 93.5%

8. Specifications

Technical Data	S6-EA1P4.6K-L
Protection	
Residual current monitoring	Yes
DC reverse polarity protection	Yes
Protection class / Over voltage category	I
Over voltage category	DC II, AC III
General data	
Dimensions(W/H/D)	440*465*192mm
Dimensions of package(W/H/D)	710*550*280mm
Weight	24.5kg
Topology	High frequency insulation
Operation temperature range	-25...+60°C
Operation temperature range	0-95%
Ingress protection	IP66
Cooling concept	Natural convection
Environmental category	Indoor and outdoor
Max.operation altitude	3000m
Active anti-islanding method	Active frequency shifting
Grid connection standard	C10/11, 50549, G98, G99, VDE4105, AS4777.2, France
Safety/EMC standard	IEC/EN 62109-1/-2, EN 61000-6-2/-3
Features	
Battery connection	Terminal Block
AC connection	Quick connection plug
Display	LED+APP
Communication	RS485,CAN, Optional: Wi-Fi, LAN
Warranty	5 years standard (extend to 20 years)

8. Specifications

Technical Data	S6-EA1P5K-L
Battery	
Battery type	Li-ion
Battery voltage range	40 - 60V
Max. charge power	5kW
Max. discharge power	5.3kW
Max. charge / discharge current	105A
Communication	CAN
Startup Voltage	40V
Output AC(Grid side)	
Rated output power	5kW
Max. apparent output power	5kVA
Operation phase	1/N/PE
Rated grid voltage	220 V/230 V
The grid voltage range	187-253 V
Rated grid frequency	50 Hz/60 Hz
AC grid frequency range	45-55 Hz/55-65 Hz
Rated grid output current	22.8 A/21.8 A
Max. output current	22.8 A/21.8 A
Inrush current	41.50A ,4.5ms
Max. output fault current	41.50A ,4.5ms
Max. output overcurrent protection	22.8 A
Power Factor	> 0.99 (0.8 leading - 0.8 lagging)
THDi	<3%
Input AC (Grid side)	
Input voltage range	187-253 V
Max. input current	22.8 A/21.8 A
Max. input power	5kW
Frequency range	45-55 Hz/55-65 Hz
Efficiency	
BAT charged/discharged to AC Max. efficiency	> 93.5%

8. Specifications

Technical Data	S6-EA1P5K-L
Protection	
Residual current monitoring	Yes
DC reverse polarity protection	Yes
Protection class / Over voltage category	I
Over voltage category	DC II, AC III
General data	
Dimensions(W/H/D)	440*465*192mm
Dimensions of package(W/H/D)	710*550*280mm
Weight	24.5kg
Topology	High frequency insulation
Operation temperature range	-25...+60°C
Operation temperature range	0-95%
Ingress protection	IP66
Cooling concept	Natural convection
Environmental category	Indoor and outdoor
Max.operation altitude	3000m
Active anti-islanding method	Active frequency shifting
Grid connection standard	C10/11, 50549, G98, G99, VDE4105, AS4777.2, France
Safety/EMC standard	IEC/EN 62109-1/-2, EN 61000-6-2/-3
Features	
Battery connection	Terminal Block
AC connection	Quick connection plug
Display	LED+APP
Communication	RS485,CAN, Optional: Wi-Fi, LAN
Warranty	5 years standard (extend to 20 years)

8. Specifications

Technical Data	S6-EA1P6K-L
Battery	
Battery type	Li-ion
Battery voltage range	40 - 60V
Max. charge power	6kW
Max. discharge power	6.3kW
Max. charge / discharge current	125A
Communication	CAN
Startup Voltage	40V
Output AC(Grid side)	
Rated output power	6kW
Max. apparent output power	6kVA
Operation phase	1/N/PE
Rated grid voltage	220 V/230 V
The grid voltage range	187-253 V
Rated grid frequency	50 Hz/60 Hz
AC grid frequency range	45-55 Hz/55-65 Hz
Rated grid output current	27.3 A/26.1 A
Max. output current	27.3 A/26.1 A
Inrush current	41.50A ,4.5ms
Max. output fault current	41.50A ,4.5ms
Max. output overcurrent protection	27.3 A
Power Factor	> 0.99 (0.8 leading - 0.8 lagging)
THDi	<3%
Input AC (Grid side)	
Input voltage range	187-253 V
Max. input current	27.3 A/26.1 A
Max. input power	6kW
Frequency range	45-55 Hz/55-65 Hz
Efficiency	
BAT charged/discharged to AC Max. efficiency	> 93.5%

8. Specifications

Technical Data	S6-EA1P6K-L
Protection	
Residual current monitoring	Yes
DC reverse polarity protection	Yes
Protection class / Over voltage category	I
Over voltage category	DC II, AC III
General data	
Dimensions(W/H/D)	440*465*192mm
Dimensions of package(W/H/D)	710*550*280mm
Weight	24.5kg
Topology	High frequency insulation
Operation temperature range	-25...+60°C
Operation temperature range	0-95%
Ingress protection	IP66
Cooling concept	Natural convection
Environmental category	Indoor and outdoor
Max.operation altitude	3000m
Active anti-islanding method	Active frequency shifting
Grid connection standard	C10/11, 50549, G98, G99, VDE4105, AS4777.2, France
Safety/EMC standard	IEC/EN 62109-1/-2, EN 61000-6-2/-3
Features	
Battery connection	Terminal Block
AC connection	Quick connection plug
Display	LED+APP
Communication	RS485,CAN, Optional: Wi-Fi, LAN
Warranty	5 years standard (extend to 20 years)

Ginlong Technologies Co., Ltd.

No. 57 Jintong Road, Binhai Industrial Park, Xiangshan, Ningbo,
Zhejiang, 315712, P.R.China.

Tel: +86 (0)574 6578 1806

Email: info@ginlong.com

Web: www.solisinverters.au

Please adhere to the actual products in case of any discrepancies in this user manual.

If you encounter any problem on the inverter, please find out the inverter S/N and contact us, we will try to respond to your question ASAP.



UK mark for conformity