

Step by Step installation guide: S5-EH1P5K + Dyness AC couple Application at single phase site

Item checklist:

1 x S5 hybrid inverter

1 x battery

1 x eastron meter SDM120CT Marked as ID 2

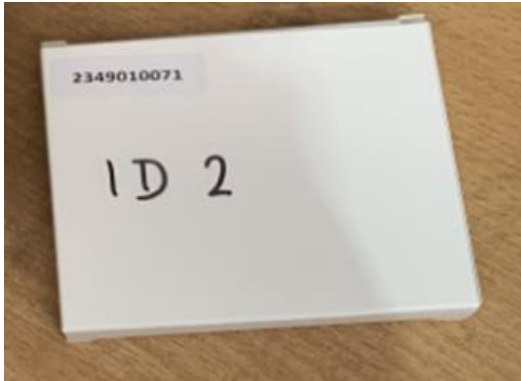

Wiring diagram

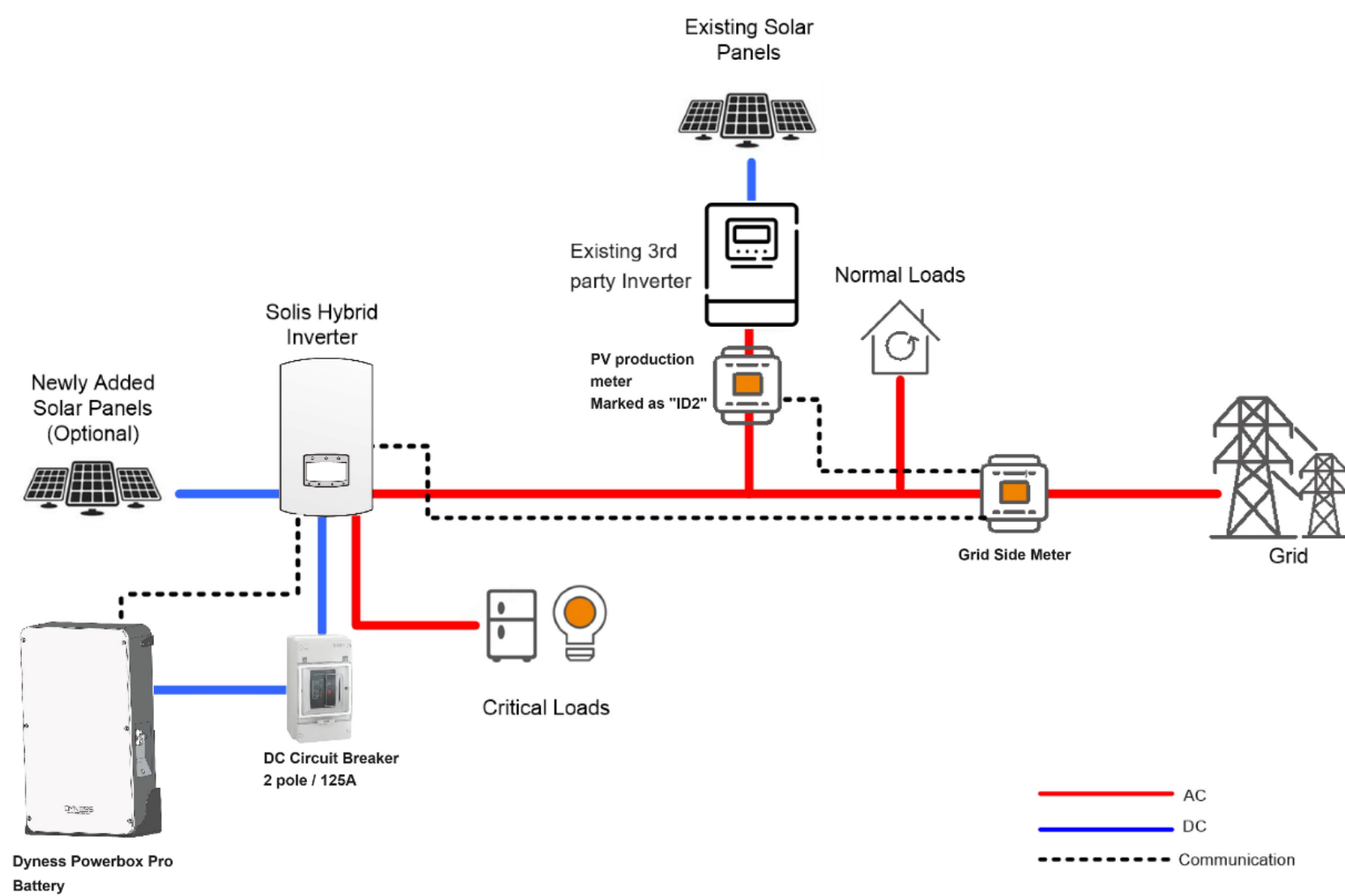

Wiring for single phase site

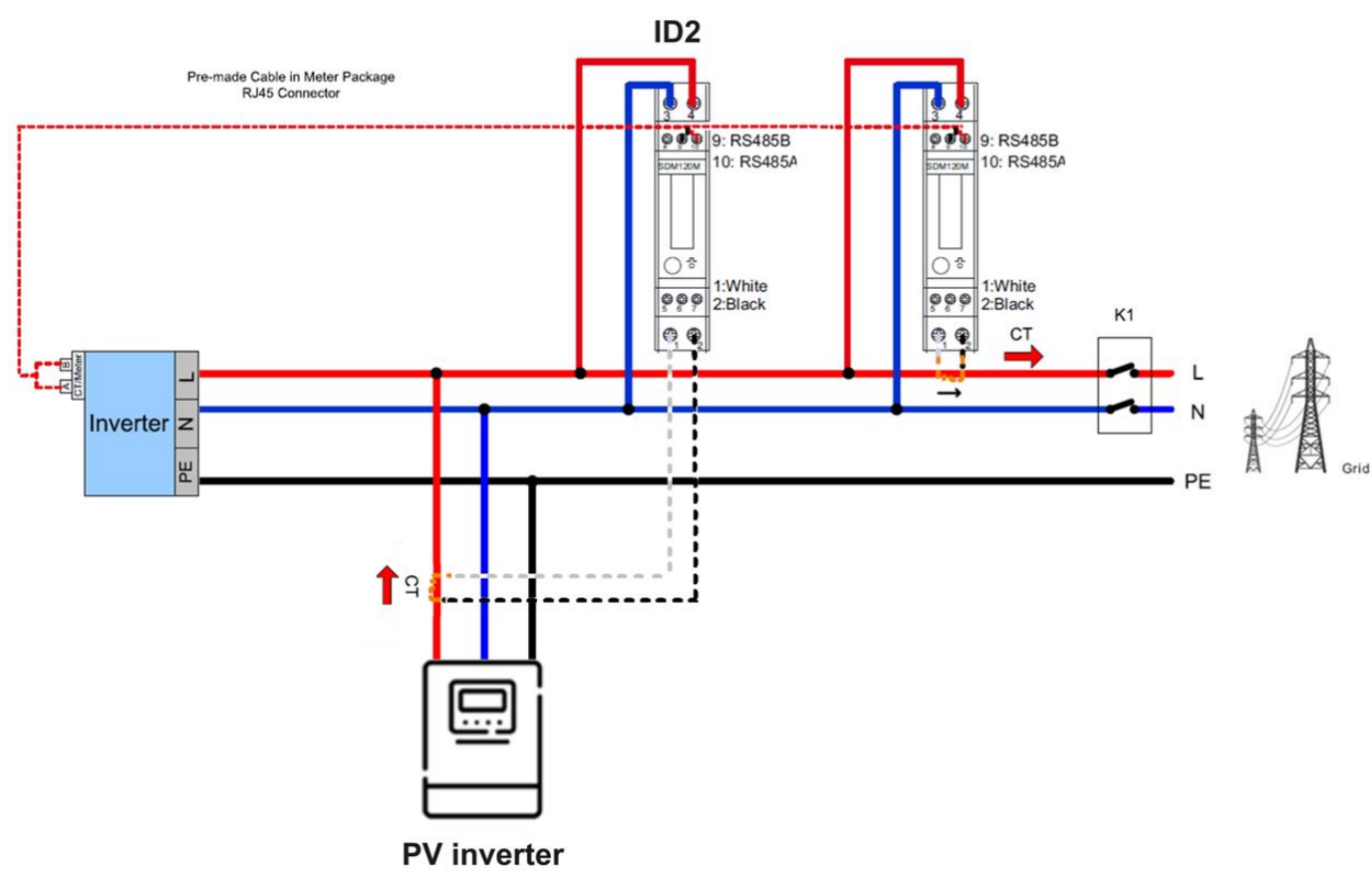

Configuration:

select meter type: Advanced Setting->Storage Energy Set->Meter Select->Eastron 1Ph Meter

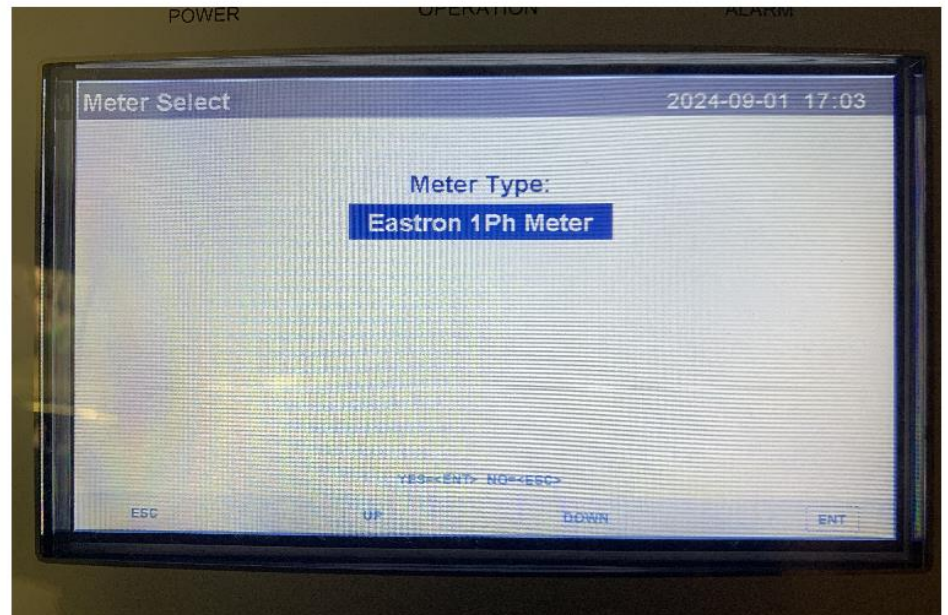
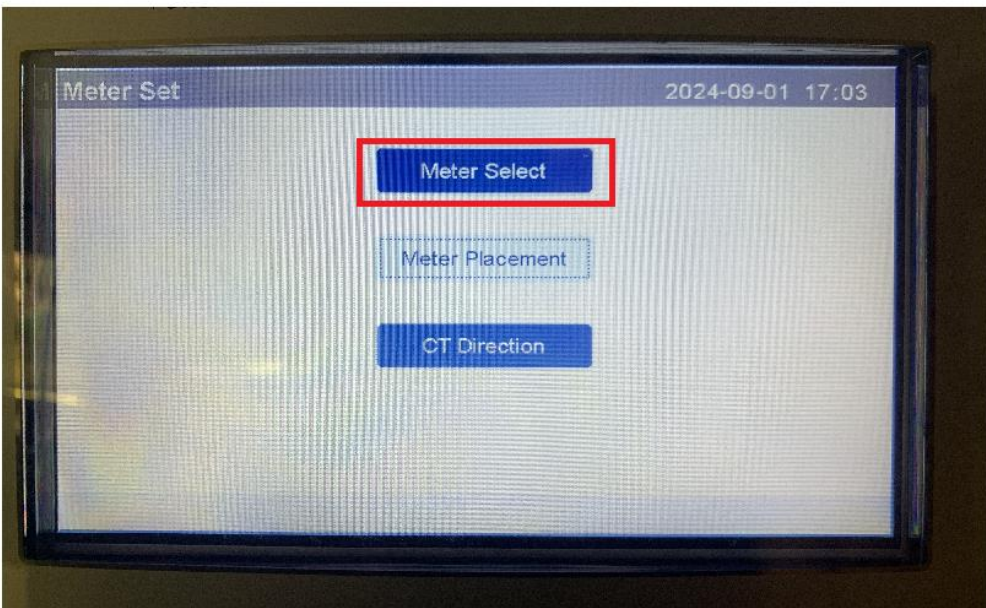
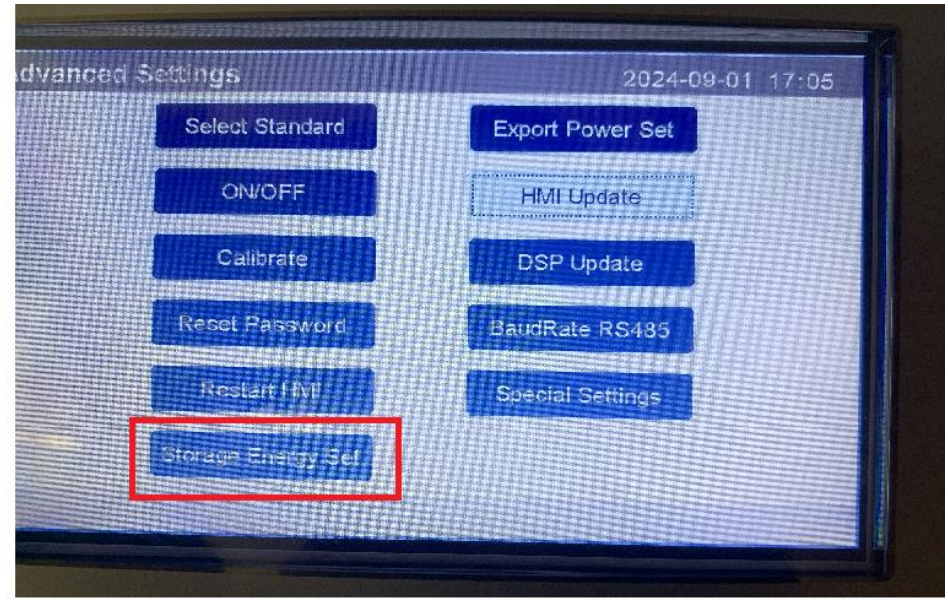
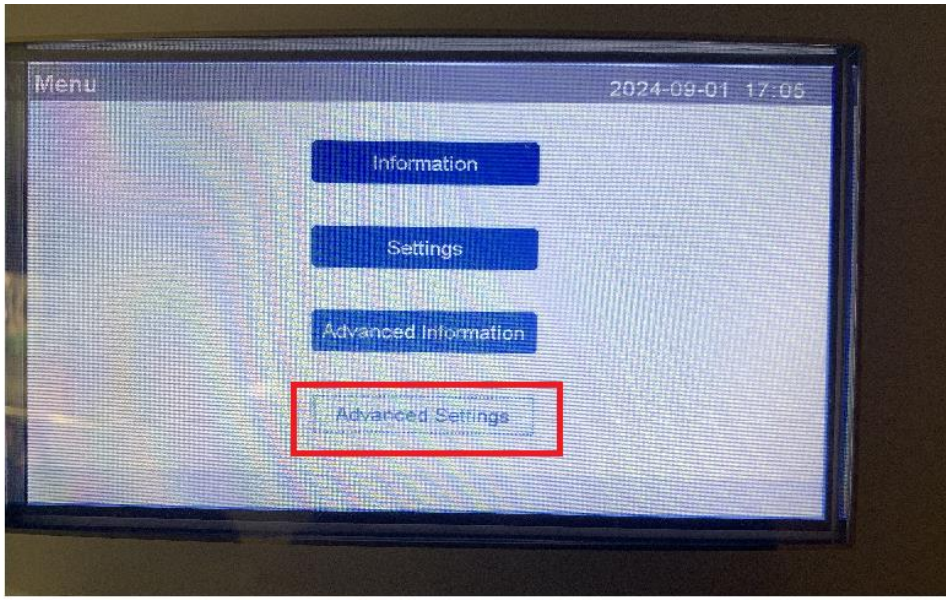

select meter location
Meter Placement -> Grid + PV Inverter

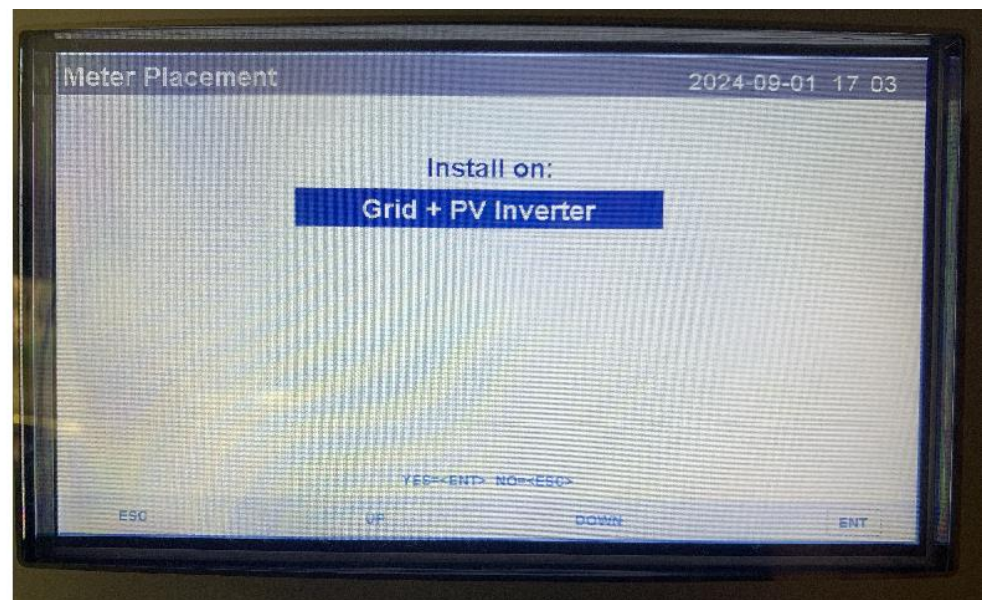
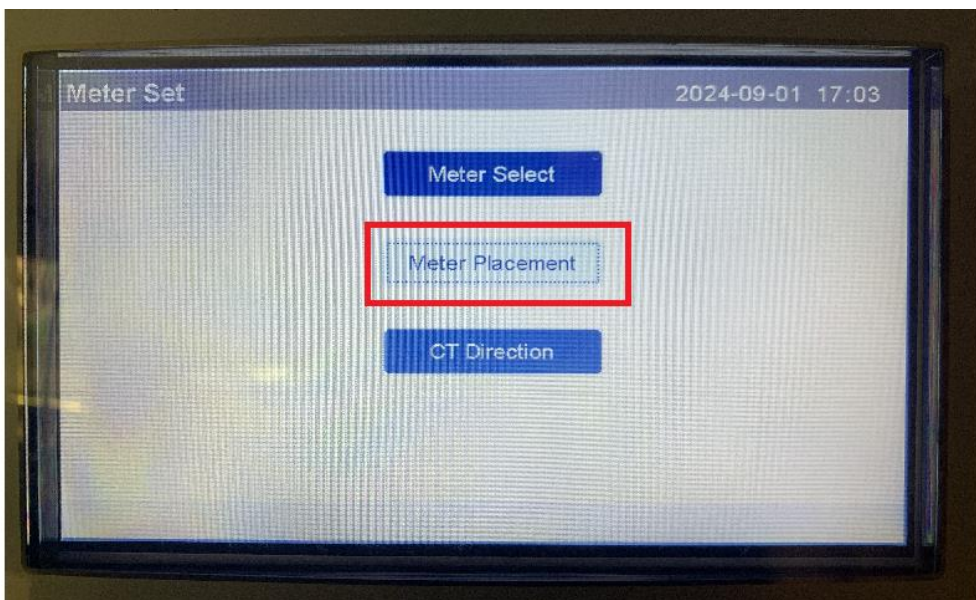

Verify meter reading
Information->page 4
Make sure you can see Grid Meter and PV Inverter Meter

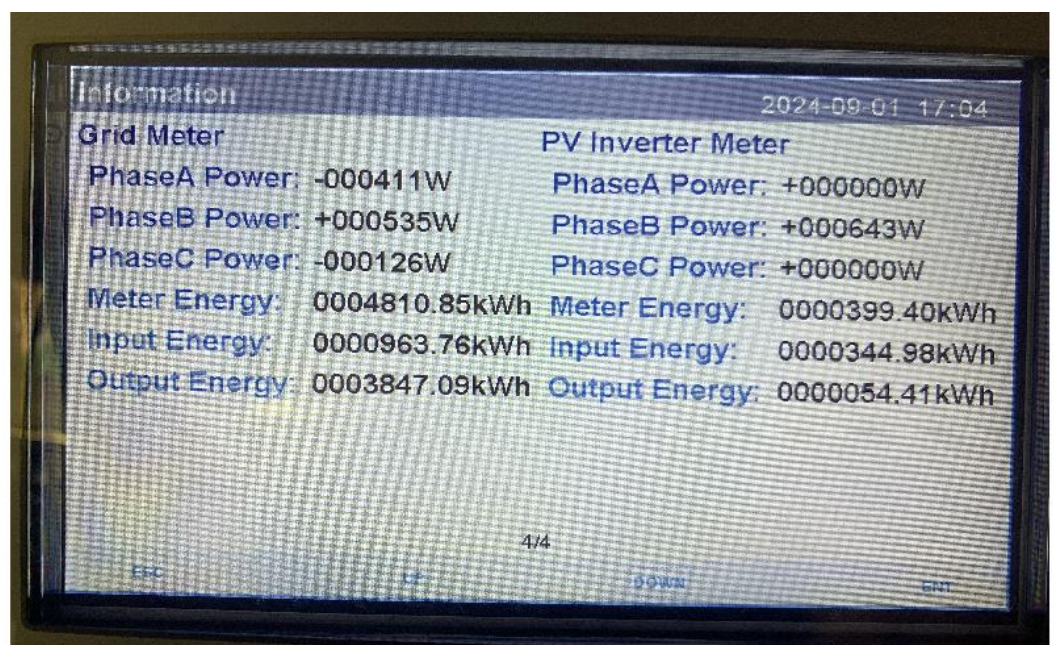
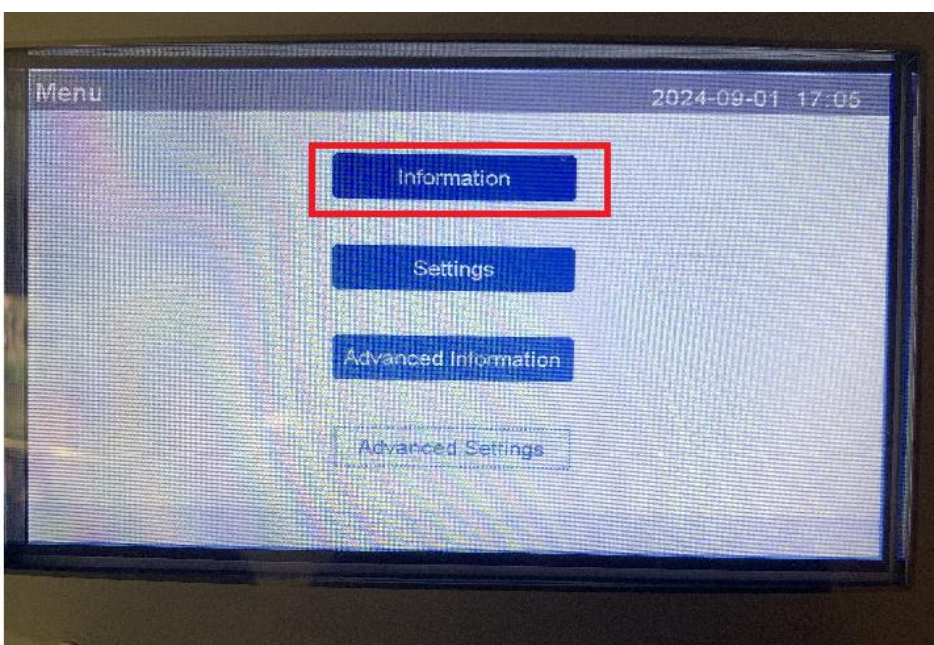

Firmware requirements, HMI firmware needs to be **4B80** to support meter location "Grid+PV" option.
Datalogger firmware needs to be updated to the latest to support 3rd party inverter production shown on the APP.
3rd party inverter production is not visible on the inverter screen