

Three Phase Meter Quick Installation Guide

-Version 1.3

1. Scope

The following models of Solis inverters have integrated the export power limitation function as well as 24hour consumption monitoring function. To enable the functions, please refer to below installation guide to install the three phase meter and follow the inverter user manual to set the inverter settings.

2. Meter Installation



NOTE:

The meter has been preset for direct installation on site. No need to change any parameters on the meter.



WARNING:

Please disconnect or switch off the upstream and downstream electrical connection before conduct the meter installation.

Otherwise there will be risk of electric shock.

The three-phase meter with CTs



System drawing

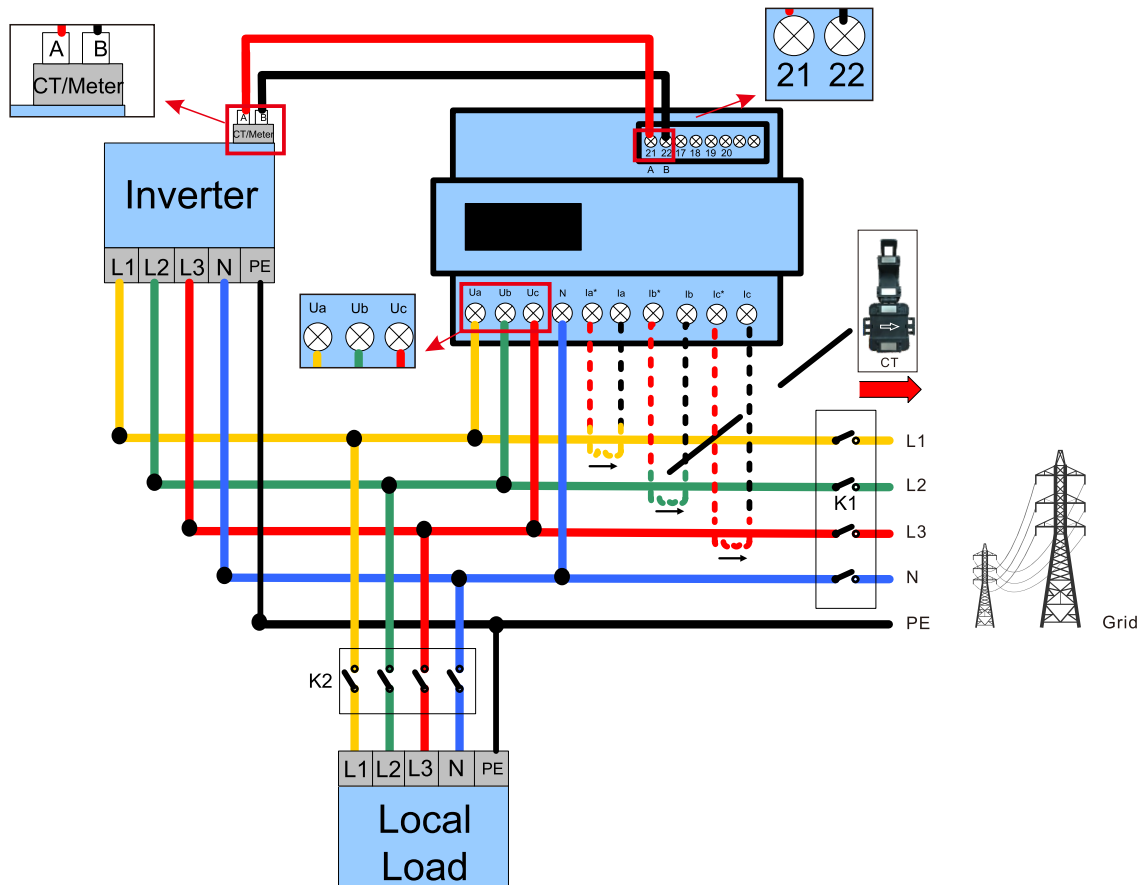

**NOTE:**

1. When connect the meter, make sure the mark "Ua", "Ub", "Uc" are connected at the grid side "L1", "L2", "L3".
2. The red cable of CT connect to the mark "Ia*", "Ib*", "Ic*", and the black cable connect to the "Ia", "Ib", "Ic".
3. The CT arrow should be towards to the Grid side.

3. Meter Specification

Model Name	DTSD1352
Grid Topology	3P+N
Rated Voltage	3*220/380V, 3*230/400V
Input Current	3*1(6)A (External CTs)
Accuracy	Voltage $\pm 0.2\%$ Current $\pm 0.2\%$ Power(P,Q,S) $\pm 0.5\%$ Active Energy Class 0.5S/1 Reactive Energy Class 2
Operating Temperature	-25°C~55°C
Relative Humidity	<95% (Non-condensing)
Dimension	126.5L*88.2W*69.5H (mm)