

## S2-PLC-CCO

### Solis PLC Central Controller

S2-PLC-CCO (CCO: Central Controller) is applied in PV systems to achieve power line communication. Power Line Communication is transmission of data over the AC Wires of the system.

#### Features:

- No need to lay communication cables, reducing construction costs and maintenance costs
- Strong anti-interference ability
- Support multi-terminal networking
- Stable network connection, real-time data transmission



S2-PLC-CCO

### Intelligent Monitoring Solution - S2-PLC-CCO

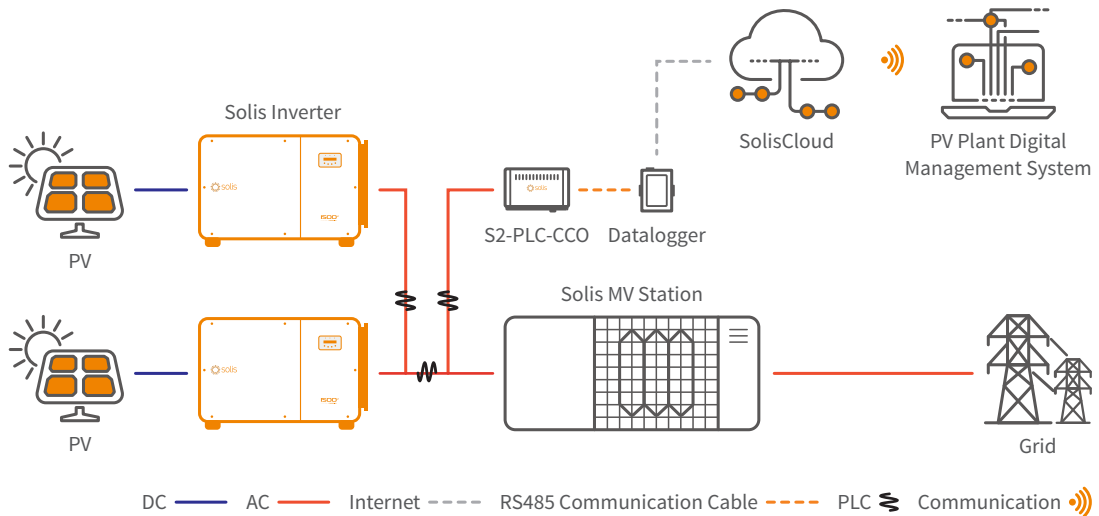

## DATASHEET

## S2-PLC-CCO

Models	S2-PLC-CCO
<b>Communication</b>	
Supported device type	Solis inverter
Number of connected inverters	≤ 80
Status indicator	4 LED Indicator Lights
Frequency band	2 - 12 MHz
Communication interface	4pin / RJ45 / RS485
Debugging interface	Bluetooth
Baud rate	9600 / 19200 / 57600 / 115200
<b>Electrical</b>	
Input voltage (Power adapter)	12 VDC
Max. input current (Power adapter)	2 A
AC port input line voltage	50 - 920 V, 50 Hz
Operating power consumption	< 5 W
<b>Environment</b>	
Operating ambient temperature range	-40 ~ +70°C
Operating humidity	5% - 95% relative humidity, non-condensing
Storage temperature	-45 ~ +90°C
Storage humidity	5% - 95% relative humidity, non-condensing
Max. operation altitude	4000 m
Protection degree	IP 20
<b>Mechanical</b>	
Dimensions (L × W × H)	255 × 165 × 45 mm
Installation method	Hanging ear mounting, rail mounting
Weight	750 g