

# Quick Installation Manual

## Version 1.1

### S2-PLC-CCO



## 1 Introduction

S2-PLC-CCO product is used for PLC (power line communication), no need for more RS485 communication cables. Can not only reduce the cost of construction and maintenance, but improve communication reliability and efficiency.

## 2 Package List

Package list is shown below:

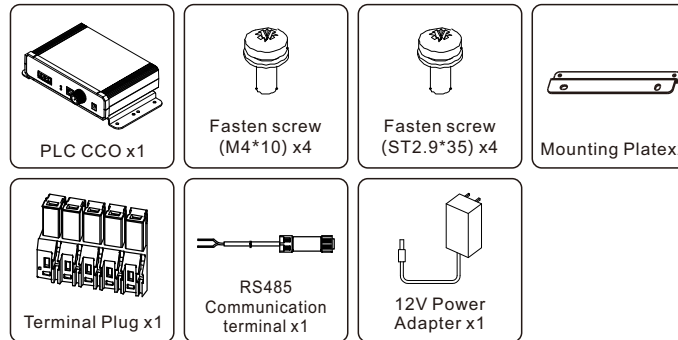

Improper use may lead to the risk of electric shock or burn. During installation and maintenance, please strictly follow the instructions in this manual. Please read this manual carefully before use and keep it safe for future reference.

## 3 Working Principle

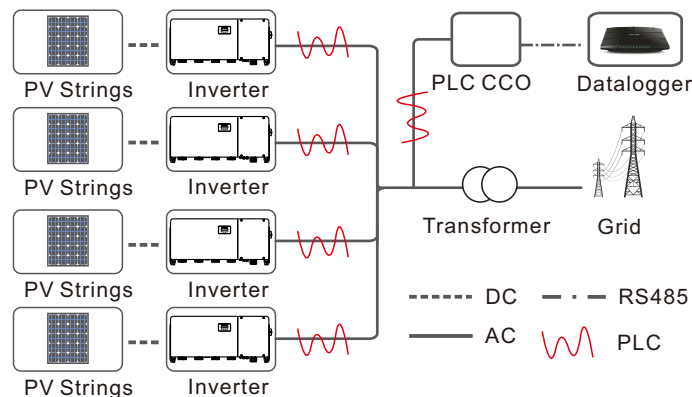

## 4 Warning

1. Ensure that it is not electrically connected and energized before installation and wiring.
2. Before wiring, make sure that the switch connected to the PLC CCO AC power line is off.
3. Must install indoors with good ventilation to prevent system performance from being affected.
4. Do not install around strong electric interference devices.
5. Do not install around a heat source.
6. Before replacing or maintaining a cable, power off the system.
7. PLC communication is not more than 1000 meters on the overhead AC cable, and not more than 500 meters on the ground AC cable.
8. PLC devices of multiple manufacturers cannot be used in the same array. If you need to use them, please contact the technical personnel in advance.
9. The PLC CCO box is connected as close as possible to the AC side of the inverter to reduce the number of circuit breakers passed by the PLC.
10. RS485 1, RS485 2, and LAN interfaces cannot be used at the same time.
11. Communication can be normal used only after the Bluetooth configuration is complete and the indicator is off.

### NOTE:

All operations on PLC CCO must be performed by professional electrical technicians. Operators should be fully familiar with the composition and working principle of the whole grid-connected PV system and relevant standards of the country/region where the project is located.

## 5 Indicator Lights

Indicators	Status
Power (red light)	Light on after power-on
	Light off when no power
Bluetooth (blue light)	Light off when disconnected
	Light flashes when connection authentication Light on after successfully authentication
Network (green light)	Light on when data in interaction
	Light off when no data
TX/RX (yellow light)	Light flash quickly when data in interaction
	Light flash slowly when timeout no reply Power-on and no data transmission or data transmission is complete: Light on

## 6 Description of wiring terminals and indicators

Panel main view

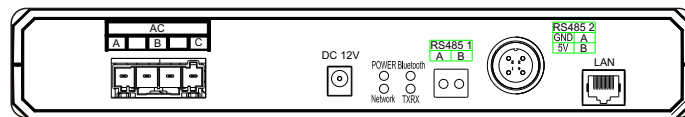

Number	Name	Function
1	AC wiring terminal	AC power cable connector, support 220V~920V
2	DC12V power terminal	PLC CCO power supply
3	RS485 1	RS485 2pin connector
4	RS485 2	RS485 4pin connector
5	LAN	Ethernet connector

## 7 PLC CCO installation

1. Fix the mounting plate and PLC box with ST2.9\*35 screws, then use the M4\*10 screw to fix the mounting plate to the installation.
2. Screw locking torque is 1.2Nm.

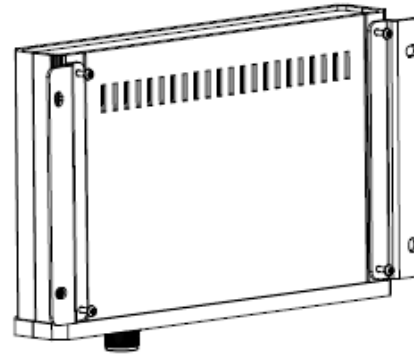

### 3. Mounting dimension

length:273.72mm,  
width:110mm,  
diameter :8mm\*6mm.

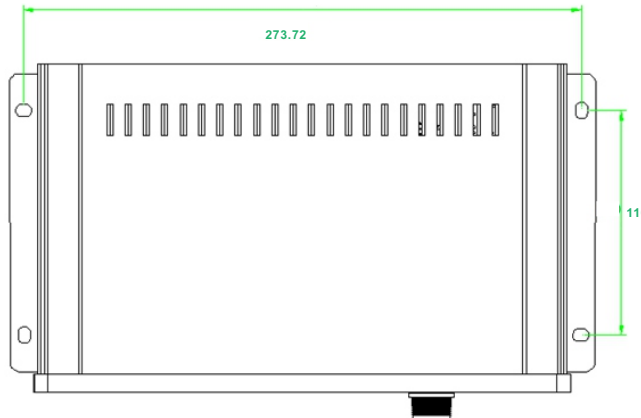

## 8 PLC CCO wiring

1. Strip off the insulation as shown below:

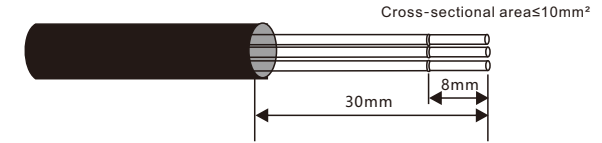

2. Use a slot type screwdriver to press the position as below, then insert the A,B,C to the pin 1,2,3.

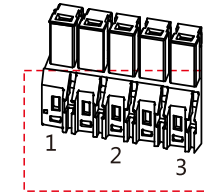

3. Connect the the terminal to the PLC CCO as shown below:

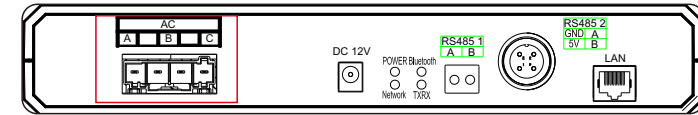

4. Connect RS 485 communication cable to "RS 485 1" (2 pin RS 485 connector) or "RS 485 2" (4 pin connector)

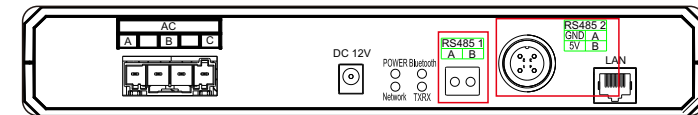

5. Connect the Ethernet communication cable to the LAN port.

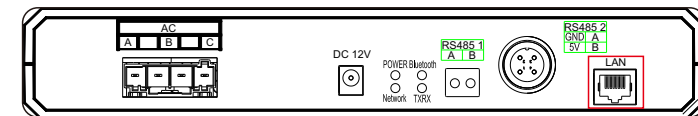

**NOTE:**

Only choose one interface for RS4851, RS485 2 and LAN.

## 9 Bluetooth connection

After the PLC CCO device is powered on, log in to the Solis cloud application: Me > More Tools > Local Operation > Connect With Bluetooth > Connected Device (P\_ device SN). The default Bluetooth password is 123456.

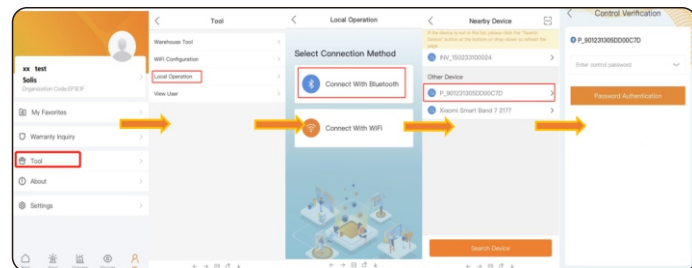

## 10 Parameter reading and configuration

### 10.1 Main Page

After login successfully you can jump into the operation page, the information as shown below:

- PLC CCO device SN
- Firmware version of PLC CCO
- MAC address of PLC CCO
- Connect diagram between the inverter-PLC CCO -data logger
- status: Communication status is normal or abnormal
- Module type: PLC CCO module type mode
- Connection status: The connection status of PLC CCO and STA device
- Inverter: Number of inverters in the connection system. Click the number of inverters to go to the "Inverter List" page
- Connection setting: The connection setting for the inverter and PLC CCO, can set the whitelist etc

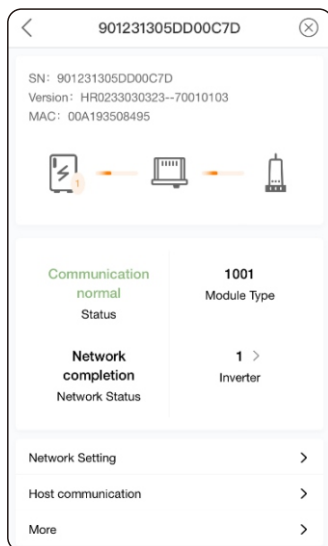

- Upper computer communication: The communication configure page between PLC CCO and PC
- More: Can change the PLC CCO Bluetooth password

### 10.2 Inverter list

Displays the number of inverters, whitelist, and detailed information about inverters in connection system.

- Inverter address range: You can manually set the address range search to avoid omissions during configuration
- Whitelist: You can click to view the current whitelist configuration and manually delete the inverter whitelist
- Inverter details: Click to view the inverter details

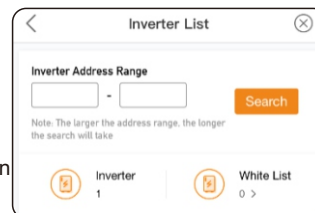

#### 10.2.1 Whitelist management

Display the current whitelist list. After entering this page, read and display the MAC address of the whitelist device (The MAC address of the inverter's PLC unit STA). You can delete the device from the whitelist by clicking the switch next to the MAC address.

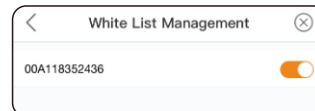

If CCO cannot retrieve the relevant information of the inverter, it is necessary to manually input the MAC address of the internal power carrier STA module of the inverter. When inputting multiple devices simultaneously, the middle should be separated by commas in English input mode.

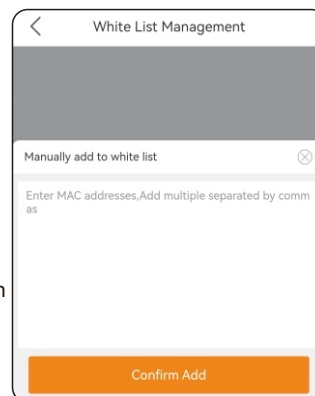

#### 10.2.2 Inverter setting

1) Show the current STA communication parameters that can be set for the inverter's PLC.

- Inverter SN
- Inverter communication address: inverter device address
- STA firmware: TBD
- STA MAC address: inverter STA MAC address
- STA communication parameter setting
- Whether to add the current inverter to the CCO whitelist

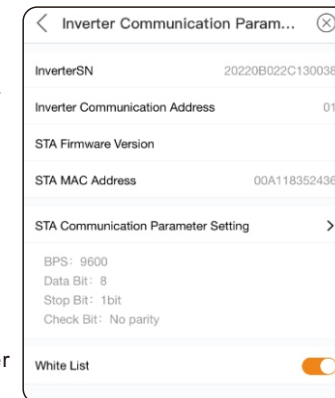

#### 10.2.3 STA communication parameter settings

Please set the relevant parameters of this interface in non-compatible mode, while maintaining consistency with the inverter.

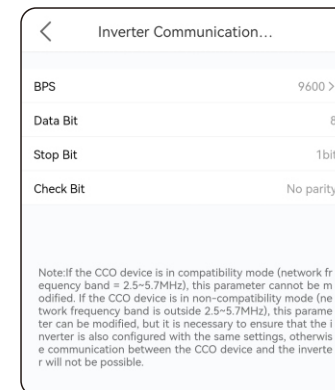

**NOTE:**

If the modification is unsuccessful or communication cannot be established after successful modification, the inverter does not support this function. Please configure this interface as the default value, baud rate: 9600; Data bit: 8; Stop bit: 1 bit; Check digit: No check. Simultaneously, the inverter needs to be kept consistent.

## 10.3 Connection system setting

- CCO communication parameter setting  
The communication parameter configuration of the PLC CCO internal power carrier module and processor needs to wait for 1 minute after modifying this parameter.
- Anti-crosstalk function (whitelist)
- Network frequency
- Whitelist management

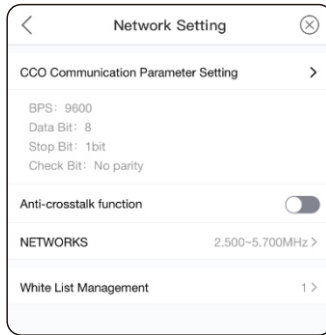

### 10.3.1 Anti-crosstalk function

Set to the on state (orange), only devices on the whitelist are allowed to communicate with PLC CCO. If set to the off state (gray), all sub devices requesting network access are allowed to communicate with PLC CCO through STA network access. Note: This function needs to be enabled after configuring the whitelist, otherwise CCO cannot automatically search for devices that are not networked.

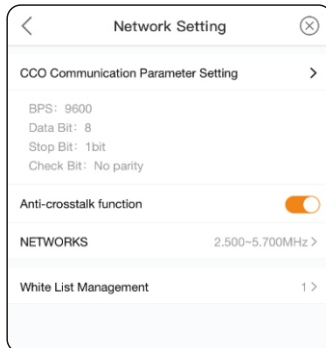

### 10.3.2 Network frequency

1.953~11.96MHz、  
2.441~5.615MHz、  
0.781~2.930MHz、  
1.758~2.930MHz、  
2.500~5.700MHz (default),  
The switching time is about 5 minutes each time. Changes are not recommended.

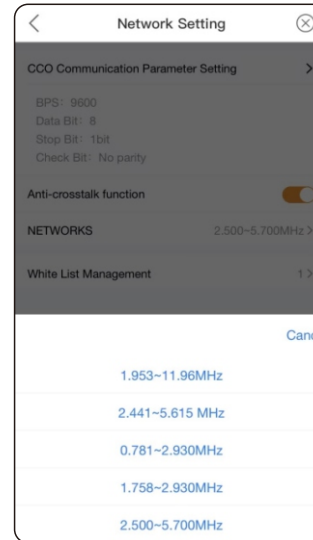

### 10.3.3 Whitelist management

Show the inverter whitelist of current CCO, can manually delete.

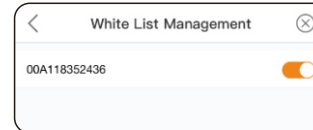

## 10.4 Upper computer communication

Communication device for PLC CCO and upper computer (data-logger), default use Modbus-RTU communication. Note: Modbus-RTU and Modbus-TCP can not use at the same time.

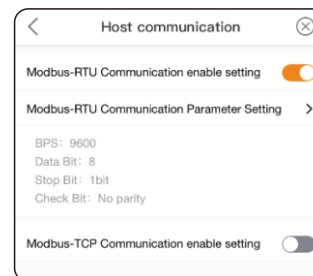

### 10.4.1 Modbus-RTU communication

- Modbus-RTU communication enable setting, after enable the function, PLC CCO and upper computer use the RS485 cable. Meanwhile, Modbus-TCP communication enable device will close automatically.
- Modbus-RTU communication parameter setting
  - 1) Baud rate: 9600 (default), 19200, 57600, 115200
  - 2) Data bits: 5, 6, 7, 8 (default)
  - 3) Stop bit: 1 bit (default), 1.5 bits, 2 bits

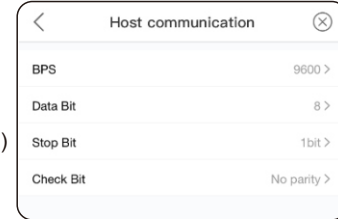

### 10.4.2 Modbus-TCP communication parameter setting

- Please configure the device address, default gateway, subnet mask and DNS according to the actual situation on site.
- Local port: port number of Modbus-TCP, default to be 502

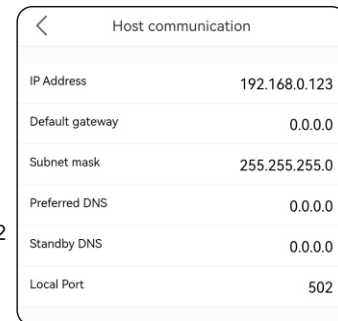

## 10.5 more

CCO Bluetooth login password modification and firmware upgrade function

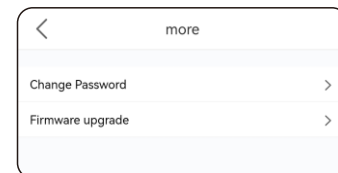

### 10.5.1 Change Password

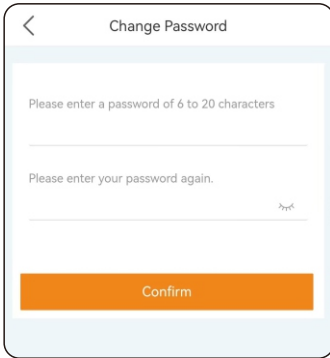

### 10.5.2 firmware upgrade

- Manual upgrade
- Check for updates

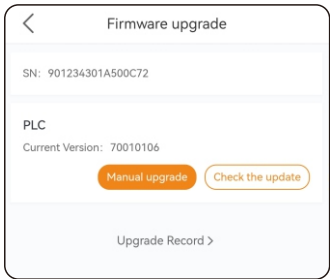

You can select the firmware version to upgrade in the "Firmware Download" section.

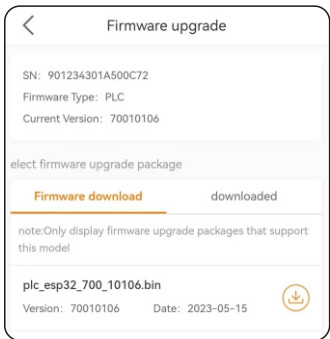

After downloading the firmware package, please click "downloaded" to select the upgrade package you want to upgrade, and click "Upgrade" to start the upgrade (do not switch the upgrade interface during the upgrade process). After the upgrade is successful, other operations can be performed.

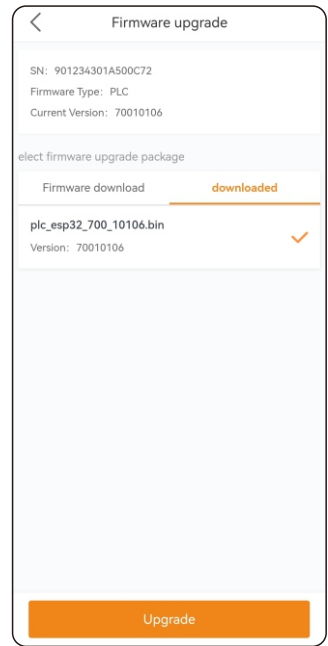

## 11 PLC CCO field application

1. To ensure stable communication between PLC CCO and inverter, all items should configure the whitelist of PLC CCO and STA according to the preceding information, and enable the anti-crosstalk function of PLC CCO.
2. The communication between PLC CCO and upper computer (data-logger) shall be selected according to the actual situation on site and the description in 10.4.
3. After all the above parameters are configured, please power off and restart the device to ensure that the parameters are modified and executed

## 12 Product parameter

Model	S2-PLC-CCO
<b>Communication</b>	
Supported device type	Solis inverter
Supported device quantity	≤80
Status display	LED×4
Band range	2MHz-12MHz
Communication port	4pin/RJ45/RS485
Debugging interface	Bluetooth
Baud rate	9600/19200/115200
<b>Electrical specification</b>	
Input voltage(Power adapter)	12Vdc
Input current(Power adapter)	2Amax
Input line voltage range (AC port)	50-920V, 50/60Hz
Consumption	< 5W
<b>Environment parameter</b>	
Operating temperature	-40°C~+70°C
Operating humidity	5%-95% relative humidity, non-condensing
Storage temperature	-45°C~+90°C
Storage humidity	5%-95% relative humidity, non-condensing
Operating altitude	≤4000 m
IP grade	IP 20

Physical parameter	
External dimension (length*width*height)	255*165*45 mm
Installation method	Mounting plates and guide rail installation
Weight	750g
Application scenarios	
Application scenarios	Double winding transformer and double split transformer
Others	
Certification	CE, FCC, UL

## 13 Contact us

---

Ginlong Technologies Co. , Ltd.  
 No. 188 Jinkai Road, Binhai Industrial Park,  
 Xiangshan, Ningbo, Zhejiang, 315712, P. R. China.  
 Tel: +86 (0) 574 6578 1806  
 Fax: +86 (0) 574 6578 1606  
 Email: [info@ginlong.com](mailto:info@ginlong.com)  
 Web: [www.solisinverters.com](http://www.solisinverters.com)